

# INTERRA

— *Developer of Uniqueness* —

## Mitsubishi Electric Air Condition Units v2

### AC - KNX Gateway

### Product Manual

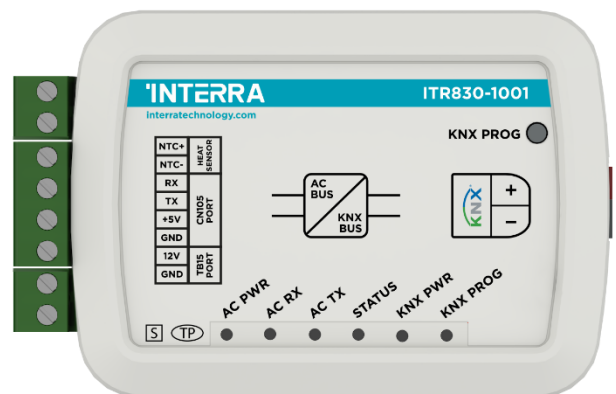

# Table of Contents

- 1. Content of The Document** ..... 5
- 2. Product Description** ..... 6
  - 2.1. Technical Information ..... 7
  - 2.2. Connection Diagram & Features ..... 8
  - 2.3 Dimensions ..... 11
- 3. ETS Parameters & Descriptions** ..... 12
  - 3.1. General Page ..... 13
    - 3.1.1. Parameters List ..... 14
  - 3.2. Logic Gate ..... 17
    - 3.2.1. Parameters List ..... 19
  - 3.3. Converter ..... 21
    - 3.3.1. Parameters List ..... 23
  - 3.4. Operating Mode ..... 26
    - 3.4.1. Parameters List ..... 32
  - 3.5. Fan ..... 38
    - 3.5.1. Parameters List ..... 39
  - 3.6. Vertical Swing ..... 41
    - 3.6.1. Parameters List ..... 43
  - 3.7. Temperature ..... 45
    - 3.7.1. Parameters List ..... 47
  - 3.8. Scenes ..... 49
    - 3.8.1. Parameters List ..... 50
  - 3.9. Special ..... 51
    - 3.9.1. Parameters List ..... 53
- 4. ETS Objects List & Descriptions** ..... 56
  - 4.1. General Objects ..... 61
  - 4.2. Logic Gate Objects ..... 63
  - 4.3. Converter Objects ..... 64
  - 4.4. Operating Mode Objects ..... 65
  - 4.5. Fan Group Objects ..... 72
  - 4.6. Vertical Swing Group Objects ..... 75
  - 4.7. Temperature Group Objects ..... 77
  - 4.8. Scene Group Objects ..... 79
  - 4.9. Special Group Objects ..... 80
- Appendix** ..... 83

Information contained in this publication regarding device applications and the like is provided only for your convenience and may be superseded versions by updates. It is your responsibility to ensure that your application meets your specifications.

INTERRA MAKES NO REPRESENTATIONS OR WARRANTIES OF ANY KIND WHETHER EXPRESS OR IMPLIED, WRITTEN OR ORAL, STATUTORY OR NONSTATUTORY, RELATED TO THE INFORMATION INCLUDING BUT NOT LIMITED TO ITS CONDITION, QUALITY, PERFORMANCE, MERCHANTABILITY OR FITNESS FOR PURPOSE.

Interra disclaims all liability arising from this information and its use. Use of Interra devices in life support and/or safety applications is entirely at the buyer's risk, and the buyer agrees to defend, indemnify and hold harmless Interra from any damages, claims, suits, or expenses resulting from such use. No licenses are conveyed, implicitly or otherwise under any Interra intellectual rights.

## Trademarks

The Interra name and logo and the Interra ITR830–1001 Mitsubishi Electric AC – KNX Gateway v2 devices are registered trademarks of Interra Technology in Türkiye and other countries.

All other trademarks mentioned herein are property of the Interra Technology.

©2025, Interra, Printed in Türkiye, All Rights Reserved.



Printed on recycled paper.

**TS EN ISO 9001:2008**

---

## TO OUR CUSTOMERS

---

One of our most important aims is to provide you with the best documentation possible to use successfully your Interra products. Focusing on this, we will keep on improving our documentation to better suit your needs. Our publications will be updated as new volumes as soon as changes are introduced.

If you have any questions or comments regarding this publication, do not hesitate to contact us:

E-mail: [info@interratechnology.com](mailto:info@interratechnology.com)

Tel: +90 (216) 326 26 40 Fax: +90 (216) 324 25 03

### Most Current Product Manual

To obtain the most up-to-date version of this product manual, please visit our Web site at:

<http://www.interratechnology.com>

You can determine the version of an Interra document by examining its literature number found on the bottom right corner of any page.

The first two letters of the literature are the type of document. The numbers that follow are the creation date of the document and the last letter is the version (e.g., PM181017001A is the version A of a product manual created on the date 17/10/18).

## 1. Content of The Document

This document contains Interra brandmark's ITR830-1001 Mitsubishi Electric AC - KNX Gateway v2 coded devices' electronic and all essential feature information for programming these products. Each subtitle is explained the characteristics of the device. Modifications of the product and special change requests are only allowed in coordination with product management.

## 2. Product Description

ITR830-1001 is an air conditioner gateway that is used for monitoring and controlling all the functioning parameters of Mitsubishi Electric Industries air conditioners via the KNX bus line.

Mitsubishi Electric AC - KNX Gateway v2 has an easy installation feature and can be installed inside the own AC indoor unit or a proper location away from the air conditioner, it connects one side directly to the electronic circuit of the AC indoor unit and in the other side directly to the KNX bus so, Mitsubishi Electric Gateway provides bidirectional communication between KNX bus and air condition system.

- Up to 5 different modes are available to determine the operating mode such as; auto, heat, cool, fan, and dry.
- ITR830-1001 have 4 logic gates to carry out logic functions with 3 different gate types such as AND, OR & XOR.
- With 4 different special modes, desired applications can be made. These modes are Energy Saver mode, Power Saver mode, Winter mode and summer mode.
- ITR830-1001 have 8 converter gates with 1 input and 1 output. Each input has 8 different data types and each output has 4 different outputs.
- Up to 5 scenes can be saved and executed from KNX, fixing the desired combination of ON/OFF, Operation Mode, Setpoint Temperature, Fan Level control, Vertical Swing Position control and Remote Controller Lock at any moment by using a simple switching with KNX bus telegram.
- Mitsubishi Electric type AC Indoor unit can be controlled simultaneously by the remote controller of the AC unit and Mitsubishi Electric Gateway.
- Mitsubishi Electric AC indoor unit monitoring from KNX, including monitoring of AC unit's state of internal variables, running working hours counter (E.g., for filter maintenance control), and error indication and error code.
- Control of the AC unit based on the ambient temperature read by the own AC unit, or in the ambient temperature read by any KNX thermostat.
- Special functions for high-level monitoring; window contact, working hours counter, standby and timer function.

## 2.1. Technical Information

The following table shows the technical information of the Mitsubishi Electric Gateway.

<b>Product Code</b>	<b>ITR830-1001</b>
<b>Power Supply</b>	KNX Power Supply
<b>Power Consumption</b>	5 mA
<b>Push Buttons</b>	1 x KNX Programming Button
<b>LED Indicators</b>	1 x KNX Programming LED 5 x Notification LEDs
<b>Type of Protection</b>	IP 20
<b>Mode of Commissioning</b>	S-Mode
<b>Temperature Range</b>	Operation (-10°C...70°C) Storage (-25°C...100°C)
<b>Maximum Air Humidity</b>	< 90 RH
<b>Colour</b>	Light Grey
<b>Dimensions</b>	88 x 62 x 27 mm (W x H x D)
<b>Certification</b>	KNX Certified
<b>Configuration</b>	Configuration with ETS

## 2.2. Connection Diagram & Features

Once the device is provided with a power supply from the KNX bus, both the physical address and the associated application program can be downloaded.

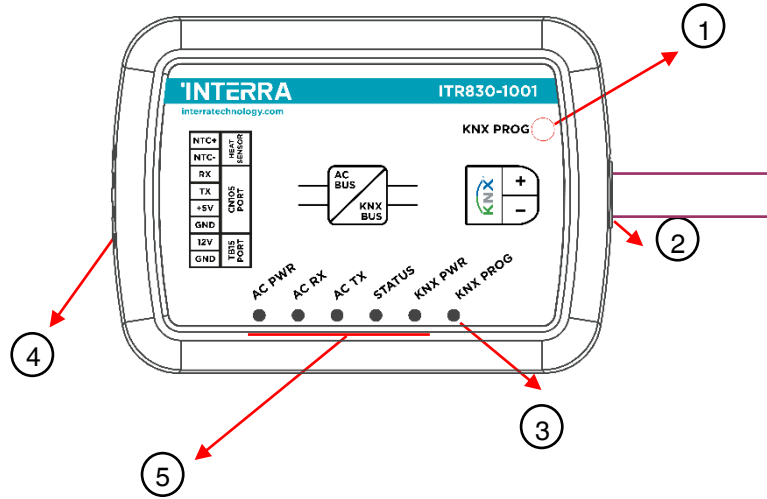
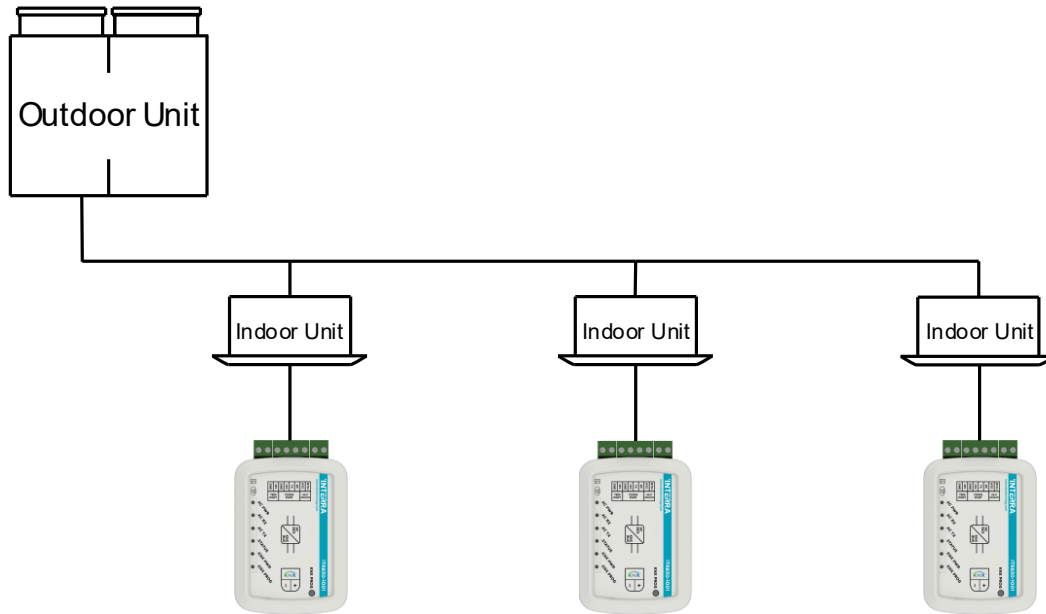

Fig. 1: Diagram of Mitsubishi Electric AC - KNX Gateway v2

Number	Feature
1	Programming Button
2	KNX Connector
3	Programming LED
4	AC Indoor Unit Connection
5	Notification LEDs

Table 1: Mitsubishi Electric AC - KNX Gateway v2 Diagram

Mitsubishi Electric AC - KNX Gateway v2 can be connected directly to the bus terminal of the AC indoor unit. Nothing that needs to do in ETS software. The following figure shows the Mitsubishi Electric Gateway connection without the remote controller.



**Fig. 2:** Mitsubishi Electric Gateway Connection Diagram without Mitsubishi Remote Controller

Mitsubishi Electric AC - KNX Gateway v2 can be connected with Mitsubishi Remote Controller to bus terminal of the AC indoor unit. In this case, the remote control unit must be selected as Master in the Mitsubishi Electric AC - KNX Gateway v2 ETS configuration. The following figure shows the Mitsubishi Electric Gateway connection with the remote controller.

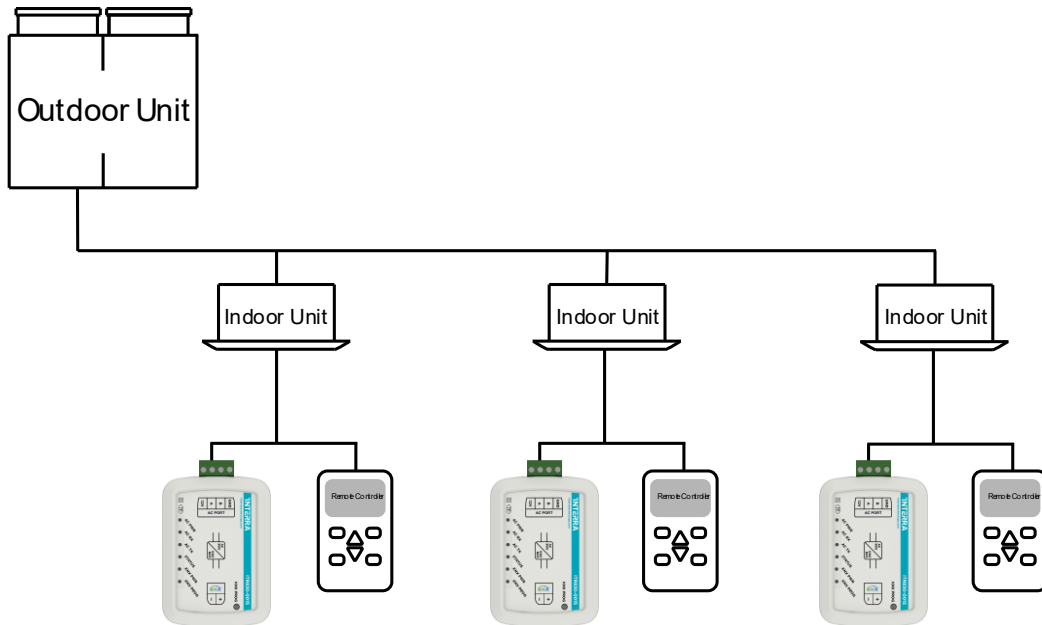

**Fig. 3:** Mitsubishi Electric Gateway Connection Diagram with Mitsubishi Electric Remote Controller

### Commissioning Instructions



- > First, disconnect the Air Conditioner from mains power.
- > Then, disconnect the power supply of the KNX bus.
- > Install the interface and connect it to the communication bus at any point of the bus. The communication bus is the bus that connects the AC indoor unit and the wired remote controller
- > Connect the KNX bus to the KNX connector of the interface according to polarity.
- > Reconnect the AC indoor unit to mains power and power supply to the KNX bus.

## 2.3 Dimensions

All values given in the device dimensions are millimetres.

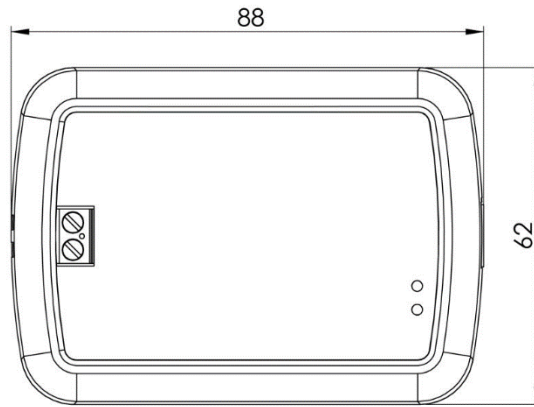

**Fig. 4:** Dimensions of Mitsubishi Electric AC - KNX Gateway from The Top View

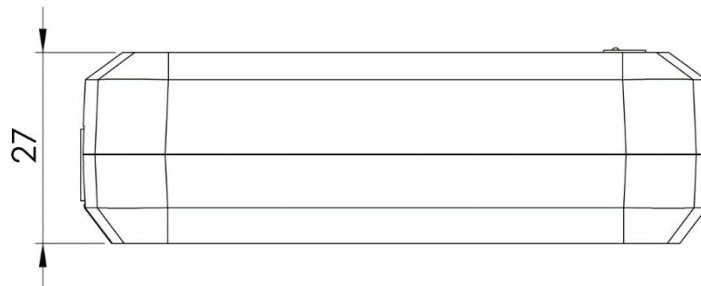

**Fig. 5:** Dimensions of Mitsubishi Electric AC - KNX Gateway v2 from The Side View

### 3. ETS Parameters & Descriptions

In this chapter, the ETS parameters of the Mitsubishi Electric AC - KNX Gateway v2 device are described using the parameter pages and options. The parameter page features are dynamic structures which means further parameters and parameter pages are enabled depending on the configuration and function of the groups.

In this section, a detailed description of the functional features of the device is given. All the parameters of the device are explained under the relevant headings.

In the ETS parameter configuration pages, each of the parameters has got a default parameter value. These default values are written in bold.

- E.g. : > Setpoint shifting      • **via parameter**      via communication object

#### Special Notes



**This is a fully compatible KNX device that must be configured and set up using the standard KNX tool ETS.**

In the following sections, there is a detailed explanation about each of the different functionalities of Mitsubishi Electric AC - KNX Gateway v2 in ETS.

### 3.1. General Page

When the Mitsubishi Electric Gateway is attached to the project from the ETS program, a configuration setting must be made primarily before loading. When entering the “GENERAL” in the parameter page, the configuration screen will be appeared shown below. Global parameter settings for the whole device are made in this window. From the general configuration window, the different advanced functionalities of the Mitsubishi Electric Gateway can be enabled such as Module alive beacon, Setting the working condition of the remote controller, Behaviours during & after bus voltage failure, Device & remote-control locking, Errors Management, Initial Configuration.

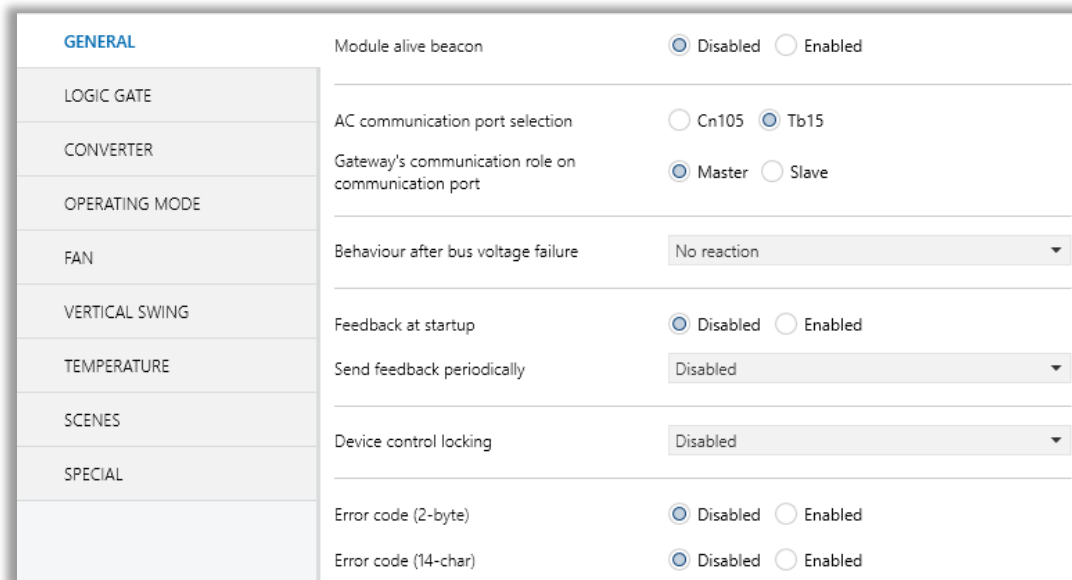



Fig. 6: General Configuration Parameter Page

### 3.1.1. Parameters List

PARAMETERS	DESCRIPTION	VALUES
Module alive beacon	This feature is used to determine whether the Mitsubishi Electric Gateway is operating. With the enabling of the module alive beacon parameter whether the device is working correctly can be known. The value true is sent with a preconfigured period via the group object. The receipt of this telegram periodically means that the device is working properly.	Disabled Enabled
> Module alive beacon interval(mm:ss)	This parameter is used to determine the time of the module alive beacon sending data.   Where the KNX bus line communication is intensive, it is more accurate to select the bigger time. Otherwise, even communication breaks may occur.	00:05...01:00...04:15
AC communication port selection	This parameter selects through which port the air conditioner is connected to the AC Gateway.	Cn105 Tb15
Gateway's communication role on communication port	This parameter is used to determine whether the Mitsubishi Electric AC Gateway and the air conditioner wired remote controller are used together. If the wired remote control is to be used, the controller must be selected as the master. This parameters only available when there is only one air conditioner unit in system.	Master Slave
Behaviour after bus voltage failure	This parameter is used to determine the action that will be taken by the gateway when the KNX bus voltage failure is recovered. If there is a power interruption or until the KNX energy comes back up, one of the following options can be applied.  <b>No Reaction/Last State:</b> The air conditioner unit retains its last condition after the power failure.  <b>Off:</b> The air conditioner will be switched off.  <b>Scene:</b> The scene with the desired conditions from 5 different scenes can be sent to the air conditioner unit. In this case, the air conditioner unit operates under these conditions after KNX bus line power failure.	No reaction Last state Scene On Off

<p>&gt; <b>Scene selection</b></p>	<p>This parameter is used to determine the appropriate scene from the 5 scenes that can be created. The selected scene conditions are applied to the air conditioner and it works under these conditions during the KNX bus line power failure.</p>	<p><b>Scene 1, Scene 2, Scene 3, Scene 4, Scene 5</b></p>
<p><b>Feedback at start-up</b></p>	<p>This parameter is used to get some status information on the air conditioning unit when the Mitsubishi Electric Gateway is started to operate. This information can be used for these purposes such as : monitoring the air conditioner from a control centre, triggering different scenarios to operate in the KNX infrastructure etc. The following describes which status information can be observed.</p> <p>Feedback Climate On/Off</p> <p>Feedback Operating Mode</p> <p>Feedback Individual Mode Auto &amp; Heat &amp; Cool &amp; Fan &amp; Dry</p> <p>Feedback Fan Speed Enumerated</p> <p>Feedback Vanes Position Enumerated</p> <p>Feedback Setpoint Temperature</p>	<p><b>Disabled</b> Enabled</p>
<p>&gt; <b>Feedback at start-up time delay(sec)</b></p>	<p>This parameter is used to set the delay between the start-up and the sending of the feedback telegrams to the KNX bus line.</p> <p> If the value is selected as '0', the feedback will be sent to the KNX bus line immediately without no waiting.</p>	<p><b>0...255</b></p>
<p><b>Send feedback periodically</b></p>	<p>This parameter is used to send feedback on the related objects periodically according to the selected time. The objects are listed in the "<b>Feedback at start-up</b>" parameter that is described above.</p>	<p><b>Disabled</b> 5sec, 10sec, 30sec, 1min, 5min, 10min, 20min, 30min, 40min, 50min, 1h, 2h, 3h, 4h, 5h, 6h, 12h, 24h</p>
<p><b>Device Control Locking</b></p>	<p>This parameter is used to lock the Mitsubishi Electric Gateway via device control locking communication object. The device is blocked and it can no longer be controlled via any telegram. The device remains in the previous status before locking until the locking is deactivated. It must be taken into consideration that the device after the</p>	<p><b>Disabled</b> Lock on Value 0 Lock on Value 1</p>

	<p>locking will take the last value received through the bus even though this value has been received during the locking time.</p> <p><b>Lock on Value 0:</b> The Gateway will be locked when the value 0 is sent.</p> <p><b>Lock on Value 1:</b> The Gateway will be locked when value 1 is sent.</p>	
<p><b>Error code (2-byte)</b></p>	<p>This parameter is used to detect and identify the faults that come from the air conditioner via a 2-byte value. Each error code has a different meaning so, all of the error code descriptions are listed please check the Appendix section in this document.</p>	<p><b>Disabled</b> Enabled</p>
<p><b>Error code (14-byte)</b></p>	<p>This parameter is used to detect and identify the faults that come from the air conditioner via a 2-byte value. Each error code has a different meaning so, all of the error code descriptions are listed please check the Appendix section in this document.</p>	<p><b>Disabled</b> Enabled</p>

### 3.2. Logic Gate

This parameter page is used to make the logical relationships between inputs & output.

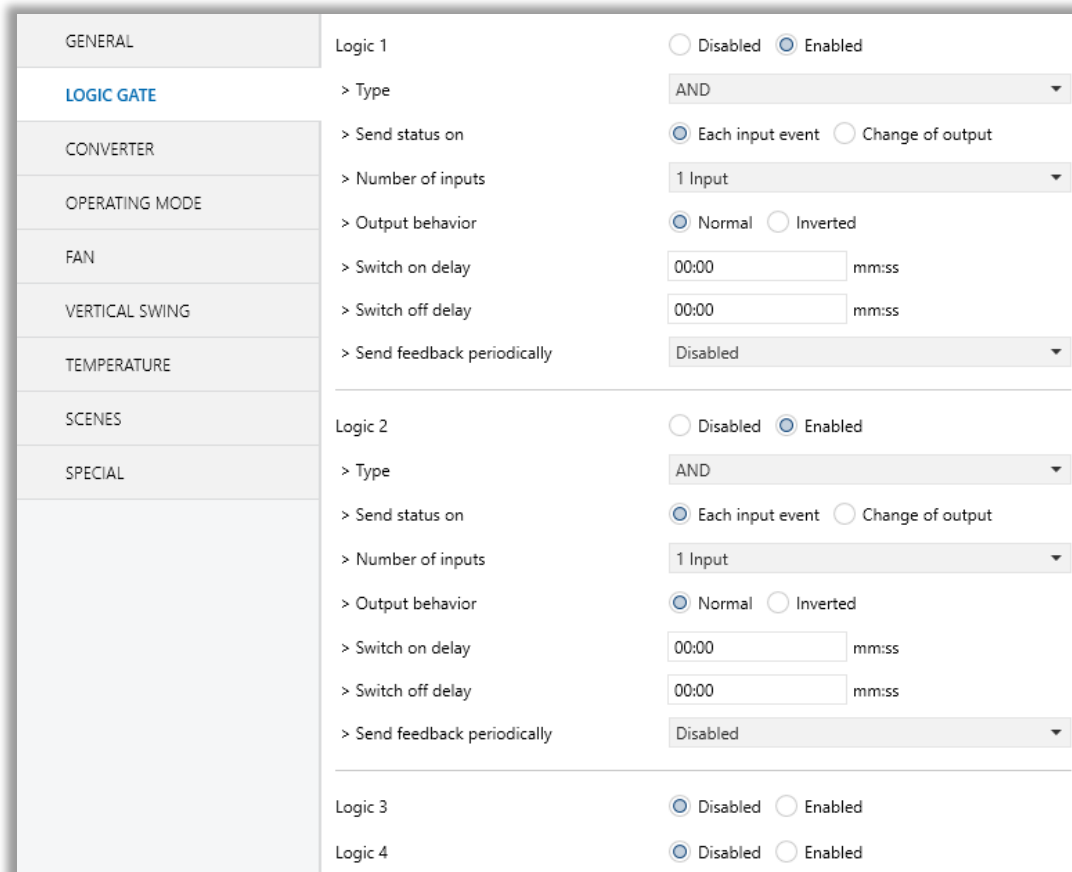

Fig. 7: Logic Gate Configuration Parameter Page

Up to 4 logic gates can be used with the gateway. In addition, each logic gate allows the use of up to 4 inputs. The standard logic operations AND, OR and XOR are available.

The status of the output of logic gates can be shown normally or inverted. This configuration can be applied via the parameter “Output behaviour” and when it is parameterized as inverted, the status of the output is shown inverted.

Through the parameter “Send status on”, the type of feedback can be defined. The gateway allows sending the result of logic gates when the conversely logic output is changed or when one of the logic inputs is modified. Additionally, it is possible to define a cyclic sending of the feedback which permits getting information about the output status periodically.

The logic output can operate with previously configured delays. The logic output takes the values ON and OFF with delays. Depending on the switch delay parameters configuration, it is possible to set an ON delay (TON), and an OFF delay (TOFF) or both at the same time.

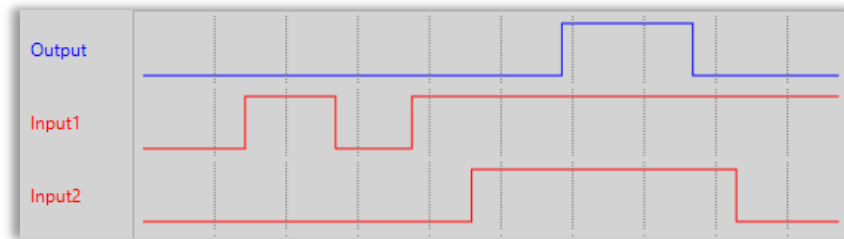

Fig. 8: Logic Gate with Delays

### Special Notes



The number of logical gates can be selected up to 4. Since the characteristics of each gate are the same, only Logic 1 is described.

### 3.2.1. Parameters List

PARAMETERS	DESCRIPTION	VALUES
Logic Gate X	This parameter is used to enable or disable the related logic function gate.	Disabled Enabled
<b>LOGIC GATE 1...4</b>		
> Type	This parameter is used to specify the type of logical gate to be used. There are 3 different logic gate types, AND, OR and XOR. Each logical gate generates a false or true value at its output as a logical association result.	AND OR XOR
> Send status on	This parameter is used to specify how the status of the output will be sent. <b>Each Input Event:</b> Output status will be sent when any logic input is received. <b>Change of Output:</b> Output status will be sent when the logic output is changed.	Each input event Change of output
> Number of inputs	This parameter is used to specify the number of inputs for the logical gate.	1 input 2 inputs 3 inputs 4 inputs
> Output behaviour	This parameter defines the behaviour of the logic output. <b>Normal:</b> The status of the output is sent without any modification. <b>Inverted:</b> If the value is true, the false value will be sent as a status value for the output or vice versa.	Normal Inverted
> Switch on delay (sec)	This parameter is used to set a delay time for output behaviour. The output takes the value ON when real-time reaches the configured time in this parameter.	0...255
> Switch off delay (sec)	This parameter is used to set a delay time for output behaviour. The output takes the value OFF when real-time reaches the configured time in this parameter.	0...255

<p>&gt;Send feedback periodically</p>	<p>This parameter is used to send feedback on the related objects periodically according to the selected time. The objects are listed in the "<b>Feedback at start-up</b>" parameter that is described on the "GENERAL" parameter page above.</p>	<p><b>Disabled</b> 5sec, 10sec, 30sec, 1min, 5min, 10min, 20min, 30min, 40min, 50min, 1h, 2h, 3h, 4h, 5h, 6h, 12h, 24h</p>
---------------------------------------	---	--

**Special Notes**



The number of logical gates can be selected up to 4. Since the characteristics of each gate are the same, only one is described.

### 3.3. Converter

The main parameter settings of the Converter Parameter page are made on this page. Various control options for the Converters are enabled from this page.

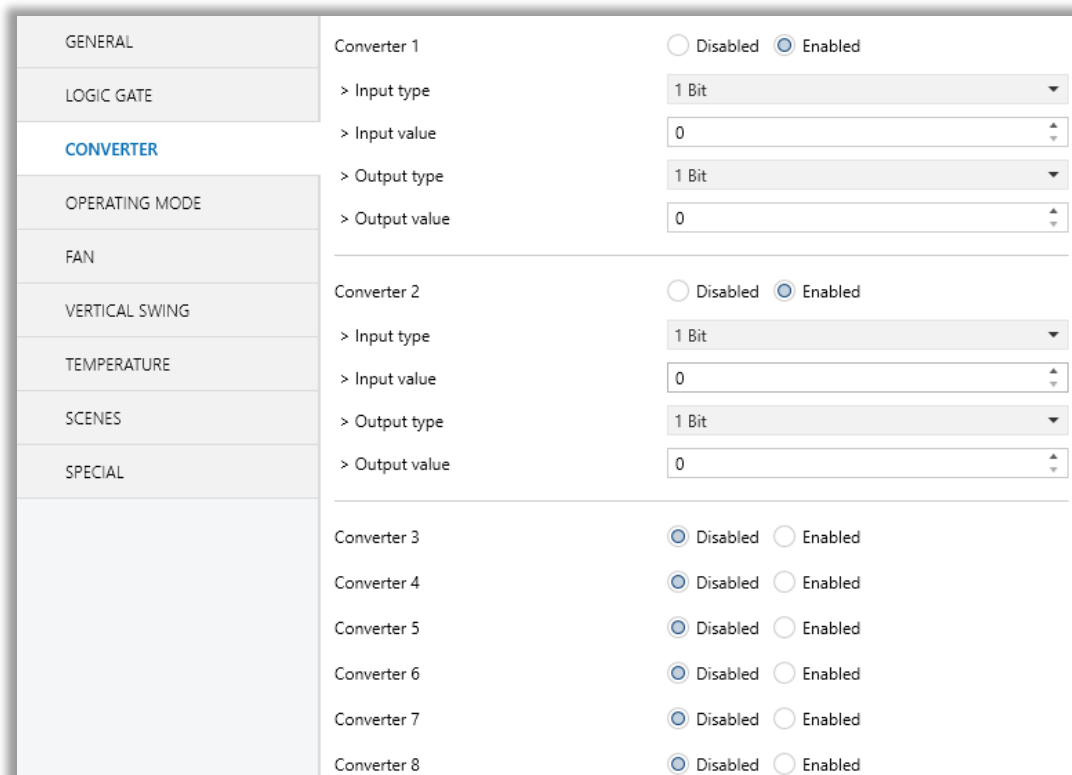

Fig. 9: Converter Configuration Parameter Page

Converters are used to convert the output to configured type value depending on the input value. There are 8 different types of data input that can be converted to 4 different data values.

Moreover, if the input is selected as 1 byte or 2 bytes, you can also make the four arithmetical operations (plus, minus, multiply, divide). Some examples are shown below :

<p><b><i>Ex 1:</i></b> Input type: 1 byte, 154 Calculation: Plus Calculation value: 7 Output type: 1 byte Output = <math>154 : 7</math> Output = 22</p>	<p><b><i>Ex 2:</i></b> Input type: 1 byte, 215 Calculation: Minus Calculation value: 51 Output type: 1 byte Output = <math>215 - 51</math> Output = 164</p>
<p><b><i>Ex 3:</i></b> Input type: 2 bytes, 862 Calculation: Multiply Calculation value: 49 Output type: 2 bytes Output = <math>862 \times 49</math> Output = 42238</p>	<p><b><i>Ex 4:</i></b> Input type: 2 bytes, 46342 Calculation: Divide Calculation value: 986 Output type: 2 bytes Output = <math>46342 : 986</math> Output = 47</p>

## Special Notes



The number of Converters can be selected up to 8. Since the characteristics of each gate are the same, only one is described.

### 3.3.1. Parameters List

PARAMETERS	DESCRIPTIONS	VALUES
Converter gate X	This parameter is used to enable or disable the related logic function gate.	Disabled Enabled
<b>CONVERTER 1...8</b>		
> Input type	<p>This parameter is used to specify the type of input value for the converter input. There are 8 different input values for each converter.</p> <p>When the input type is configured as 1-byte or 2-byte logic, the output data type is set as 1 bit. If the input value is non-zero, the output value will be 1. Otherwise, it will be zero.</p>	1 Bit 2 Bit 1 Byte 2 Byte 1 Byte Logic 2 Byte Logic 1 Byte Threshold 2 Byte Threshold
> Input value	<p>This parameter is used to set the value of the converter input. Several value types can be selected and these possible values are described below.</p> <p><b>The input type is 1 Bit:</b> If the input type is selected as 1 bit, values are between 0-1.</p> <p><b>The input type is 2 Bit:</b> If the input type is selected as 2 bits, values are between 0-3.</p> <p><b>The input type is 1 Byte:</b> If the input type is selected as 1 byte, values are between 0-255.</p> <p><b>The input type is 2 Byte:</b> If the input type is selected as 2 bytes, values are between 0-65536.</p> <p><b>The input type is 1 Byte logic:</b> If the input type is selected as 1-byte logic, values are between 0-255.</p> <p><b>The input type is 2 Byte logic:</b> If the input type is selected as 2-byte logic, values are between 0-65536.</p>	0...1 0...3 0...255 0...65535

	<p><b>The input type is 1 Byte Threshold:</b> If the input type is selected as a 1-byte threshold, values are between 0-255.</p> <p><b>The input type is 2 Byte Threshold:</b> If the input type is selected as the 2-byte threshold, values are between 0-65536.</p>	
<b>Calculation</b>	<p>This parameter is used to perform a mathematical operation with the input value.</p> <p><b>Disabled:</b> The calculation value is disabled. The input value is converted to output value without a mathematical operation.</p> <p><b>Plus:</b> The calculation value is summed with the input value.</p> <p><b>Minus:</b> The calculation value is subtracted from the input value</p> <p><b>Multiply:</b> Input value and calculation value are multiplied and the result is applied to the output value.</p> <p><b>Divide:</b> The input value is divided by the calculation value and the result is applied to the output value.</p>	<p><b>Disabled</b></p> <p>Plus</p> <p>Minus</p> <p>Multiply</p> <p>Divide</p>
<b>Calculation Value</b>	<p>This parameter is used to specify the value to be processed along with the input value. This value type is the same as the output value type.</p>	<p>0...255</p> <p>0...65535</p>
<b>Lower Limit</b>	<p>This parameter is used to set the lower limit value of the threshold for the input when the input is configured as 1 byte or 2-byte threshold.</p>	<p>0...255</p> <p>0...65535</p>
<b>Higher Limit</b>	<p>This parameter is used to set the higher limit value of the threshold for the input when the input is configured as 1 byte or 2-byte threshold.</p>	<p>0...255</p> <p>0...65535</p>
<b>Output type</b>	<p>This parameter is used to specify the type of output value for the converter output. There are 4 different output values for each converter.</p>	<p><b>1 Bit</b></p> <p>2 Bit</p> <p>1 Byte</p> <p>2 Byte</p>

<p><b>Output value</b></p>	<p>This parameter is used to set the value of the converter output. Several value types can be selected and these possible values are described below.</p> <p><b>The output type is 1 Bit:</b> If the input type is selected as 1 bit, values are between 0-1.</p> <p><b>The output type is 2 Bit:</b> If the input type is selected as 2 bits, values are between 0-3.</p> <p><b>The output type is 1 Byte:</b> If the input type is selected as 1 byte, values are between 0-255.</p> <p><b>The output type is 2 Byte:</b> If the input type is selected as 2 bytes, values are between 0-65536.</p>	<p>0...1</p> <p>0...3</p> <p>0...255</p> <p>0...65535</p>
----------------------------	--	---

### 3.4. Operating Mode

In this section, all of the parameters are corresponding to different mode properties and communication objects. Some parameters of related objects and their tasks are described below.

- **Operating Mode Heat/Cool object (1 bit):** The operating mode of the air conditioner can be selected as the heating mode or cooling mode with this 1-bit object.
- **Operating mode +/- object (1 bit):** Using this object 5 different operating modes can be selected. The selection can be made with 1-bit values. Switching between the modes is done according to the following condition :

GENERAL	Operating mode Heat/Cool object (1-bit)	Disabled
LOGIC GATE	Operating mode +/- object (1-bit)	Disabled
CONVERTER	Operating mode individual objects (1-bit)	<input type="radio"/> Disabled <input checked="" type="radio"/> Enabled
<b>OPERATING MODE</b>		
FAN	Operating mode object (1-byte)	<input type="radio"/> Disabled <input checked="" type="radio"/> Enabled
VERTICAL SWING	Operating mode percent value objects	<input type="radio"/> Disabled <input checked="" type="radio"/> Enabled
TEMPERATURE	> Priority to "Operating mode Heat/Cool"	<input checked="" type="radio"/> Disabled <input type="radio"/> Enabled
SCENES	Feedback operating mode individual objects (1-bit)	<input type="radio"/> Disabled <input checked="" type="radio"/> Enabled
SPECIAL	Feedback operating mode object (1-byte)	<input type="radio"/> Disabled <input checked="" type="radio"/> Enabled
	Feedback operating mode text object (14-char)	<input checked="" type="radio"/> Disabled <input type="radio"/> Enabled
	Energy Saver mode	<input type="radio"/> Disabled <input checked="" type="radio"/> Enabled
	> Polarity	<input checked="" type="radio"/> 1:Start / 0:Stop <input type="radio"/> 0:Start / 1:Stop
	> Working Duration Time Limit	Disabled
	> Setpoint shifting	<input checked="" type="radio"/> Via parameter <input type="radio"/> Via communication object
	> Value (°C)	1
	> Fan speed	<input checked="" type="radio"/> Via parameter <input type="radio"/> Via communication object
	> Value (fan)	No change
	Power Saver mode	<input checked="" type="radio"/> Disabled <input type="radio"/> Enabled
	Winter mode	<input checked="" type="radio"/> Disabled <input type="radio"/> Enabled
	Summer mode	<input checked="" type="radio"/> Disabled <input type="radio"/> Enabled

Fig. 10: Operating Modes Configuration Page

**Special Notes**



The operating mode of air conditioner can not be setted when gateway is slave.

- Operating Mode Individual objects (1-bit): The operating mode can be modified by sending value 1 to the desired mode object.
- Operating Mode: The operating mode can be modified with these values that are shown in the table below:

OPERATING MODE	VALUE
AUTO	0
HEAT	1
COOL	3
FAN	9
DRY	14

Table 2: Operating Mode List

- Operating Mode Percent Value Objects: Via these 1-byte objects the indoor unit can be controlled via percentage values to provide compatibility with the thermostat that uses this data type. By using this object, there are two different options:
- Priority to "Operating mode Heat/Cool": Disabled

When the priority of "Operating mode Heat/Cool" is disabled, it does not matter what is the current mode of the indoor unit, the percentage values can switch the mode and activate the indoor unit in the following way:

- If the object "Heating Mode Percent Value" takes a value greater than 0, the indoor unit will be switched ON in HEAT mode. The value 0 will switch off the air conditioner.
- If the object "Cooling Mode Percent Value" takes a value greater than 0, the indoor unit will be switched ON in COOL mode. The value 0 will switch off the air conditioner.

## Special Notes



When the priority is disabled and the air condition unit is working as FAN, AUTO or DRY modes, a new value to the objects "Heating/Cooling Mode Percent Value" or "Operating Mode Heat/Cool" will change the mode to HEAT or COOL.

- Priority to "Operating mode Heat/Cool": Enabled

When the priority is enabled, the operating mode defined cannot be modified by the percentage value objects and the behaviour will be as follow:

Actual operating mode as HEAT;

- If the object "Heating Mode Percent Value" takes a value greater than 0, the indoor unit will be switched ON. The value 0 will switch off the air conditioner.

- Any data received via the object “Cooling Mode Percent Value” will not be taken into consideration.

Actual operating mode as COOL;

- If the object “Cooling Mode Percent Value” takes a value greater than 0, the indoor unit will be switched ON. The value 0 will switch off the air conditioner.
- Any data received via the object “Heating Mode Percent Value” will not be taken into consideration.

## Special Notes



When the priority is enabled and the air condition unit is working as FAN, AUTO or DRY modes, a new value to the objects “Heating/Cooling Mode Percent Value” will not be taken into consideration. Only a new value to the object “Operating Mode Heat/Cool” will change the mode to HEAT or COOL.

## Special Notes



Any modification on all above objects will be advised in the following feedback objects:

Feedback Operating Mode Heat/Cool  
Feedback Individual Mode Auto  
Feedback Individual Mode Heat  
Feedback Individual Mode Cool  
Feedback Individual Mode Fan  
Feedback Individual Mode Dry  
Feedback Operating Mode  
Feedback Operating Mode Text

In this parameter configuration page, there are also some different special modes for operating the air conditioner. These 4 different modes are described below respectively.

***Energy Saver Mode:*** The energy saver mode can be applied via the object “Energy Saver Mode”. This mode can be configured to work during a period or the “stop” value is received. Via the parameter or via communication object “Timer” period can be set. If the timer is disabled, the “Energy Saver Mode” will be finished at the following actions:

- The object “Energy Saver Mode” receives the “stop” value, the mode will stop and the previous state will be recovered at this moment.
- A new value for fan, mode or set point is received via KNX, the Energy Saver Mode will stop and the new value will be applied at this moment.

If the timer is enabled, the energy saver mode will be finished at the below situation or once the time is elapsed. Then the previous state will be recovered. The timer can always be re-triggerable by sending the start value to the object “Energy Saver Mode”.

The timer, variation of the setpoint and the fan speed to be applied during the energy saver mode can be selected via parameter or communication object. With this last option, the user could modify the values at any time as required.

### Special Notes



If the timer, setpoint shifting or fan speed values are modified via their respective objects (“Energy Saver Mode Timer Duration”, “Energy Saver Mode Setpoint Shifting” and “Energy Saver Mode Fan Speed”) while the energy saver mode is active, the new values will be directly applied.

***Power Saver Mode:*** The power saver mode can be applied via the object “. This mode can be configured to work during a period or during the “stop” value is received. Via the parameter “Timer” period can be selected. If the timer is disabled, the “Power Saver Mode” will be finished at the following actions:

- The object “Power Saver Mode” receives the “stop” value, the mode will stop and the previous state will be recovered at this moment.
- A new value for fan, mode or set point is received via KNX, the Power Saver Mode will stop and the new value will be applied at this moment.

If the timer is enabled, the energy saver mode will be finished at the below situation or once the time is elapsed. Then the previous state will be recovered. The timer can always be re-triggerable by sending the start value to the object “Power Saver Mode”.

The timer, variation of the setpoint and the fan speed to be applied during the energy saver mode can be selected via parameter or communication object. With this last option, the user could modify the values at any time as required.

### Special Notes



If the timer, setpoint shifting or fan speed values are modified via their respective objects (“Power Saver Mode Timer Duration”, “Power Saver Mode Setpoint Shifting” and “Power Saver Mode Fan Speed”) while the energy saver mode is active, the new values will be directly applied.

***Winter Mode:*** The winter mode can be applied via the object “Winter Mode”. If the winter mode is applied while the operating is mode is COOL, the mode will be automatically changed to HEAT mode and the unit indoor will switch on.

This mode can be configured to work during a period or the “stop” value is received. Via the parameter “Timer for winter mode,” this can be selected. If the timer is disabled, the winter mode will be finished once the object “Winter Mode” receives the “stop” value. At this moment the mode will stop and the previous state will be recovered.

If the timer is enabled, the winter mode will be finished at bellow action or once the time is elapsed. Then the previous state will be recovered.

- A new value for fan, mode or set point is received via KNX or remote control will be directly applied and then the winter mode will be disabled. However, the previous status will be recovered and the air conditioner will remain the winter mode values applied.

The timer, setpoint and the fan speed to be applied during the winter mode can be selected via parameter or communication object. With this last option, the user could modify the values every time as required.

## Special Notes



If the timer, setpoint or fan speed values are modified via their respective objects (“Winter Mode Timer Duration”, “Winter Mode Setpoint Shifting” and “Winter Mode Fan Speed”) while the winter mode is active, the new values will be directly applied.

**Summer Mode:** The summer mode can be applied via the object “Summer Mode”. If the summer mode is applied while the operating is mode is HEAT, the mode will be automatically changed to COOL mode and the unit indoor will switch on.

This mode can be configured to work during a period or the “stop” value is received. Via the parameter “Timer for summer mode,” this can be selected. If the timer is disabled, the “Summer Mode” will be finished once the object “Summer Mode” receives the “stop” value. At this moment the mode will stop and the previous state will be recovered.

If the timer is enabled, the summer mode will be finished at below action or once the time is elapsed. Then the previous state will be recovered.

- A new value for fan, mode or set point is received via KNX or remote control will be directly applied and then the winter mode will be disabled. However, the previous status will be recovered and the air conditioner will remain the winter mode values applied.

The timer, setpoint and the fan speed to be applied during the winter mode can be selected via parameter or communication object. With this last option, the user could modify the values every time as required.

## Special Notes



If the timer, setpoint or fan speed values are modified via their respective objects (“Summer Mode Timer Duration”, “Summer Mode Setpoint Shifting” and “Summer Mode Fan Speed”) while the summer mode is active, the new values will be directly applied.

All parameters described in this section are set on the operating mode parameter page. The operating mode parameter page is shown below:

GENERAL	Operating mode Heat/Cool object (1-bit)	Disabled
LOGIC GATE	Operating mode +/- object (1-bit)	Disabled
CONVERTER	Operating mode individual objects (1-bit)	<input type="radio"/> Disabled <input checked="" type="radio"/> Enabled
<b>OPERATING MODE</b>	Operating mode object (1-byte)	<input type="radio"/> Disabled <input checked="" type="radio"/> Enabled
FAN	Operating mode percent value objects	<input type="radio"/> Disabled <input checked="" type="radio"/> Enabled
VERTICAL SWING	> Priority to "Operating mode Heat/Cool"	<input checked="" type="radio"/> Disabled <input type="radio"/> Enabled
TEMPERATURE	Feedback operating mode individual objects (1-bit)	<input type="radio"/> Disabled <input checked="" type="radio"/> Enabled
SCENES	Feedback operating mode object (1-byte)	<input type="radio"/> Disabled <input checked="" type="radio"/> Enabled
SPECIAL	Feedback operating mode text object (14-char)	<input checked="" type="radio"/> Disabled <input type="radio"/> Enabled
	Energy Saver mode	<input type="radio"/> Disabled <input checked="" type="radio"/> Enabled
	> Polarity	<input checked="" type="radio"/> 1:Start / 0:Stop <input type="radio"/> 0:Start / 1:Stop
	> Working Duration Time Limit	Disabled
	> Setpoint shifting	<input checked="" type="radio"/> Via parameter <input type="radio"/> Via communication object
	> Value (°C)	1
	> Fan speed	<input checked="" type="radio"/> Via parameter <input type="radio"/> Via communication object
	> Value (fan)	No change
	Power Saver mode	<input checked="" type="radio"/> Disabled <input type="radio"/> Enabled
	Winter mode	<input checked="" type="radio"/> Disabled <input type="radio"/> Enabled
	Summer mode	<input checked="" type="radio"/> Disabled <input type="radio"/> Enabled

Fig. 11: Operating Mode Parameter Page

Special Notes



All of the parameters of energy saver mode in the above parameter page image are the same for winter, power saver and summer mode. When these modes are activated, the parameters will appear.

**3.4.1. Parameters List**

PARAMETERS	DESCRIPTION	VALUES
<b>Operating mode Heat/ Cool object (1-bit)</b>	<p>This parameter is used to enable or disable the operating mode heat/cool and its feedback objects.</p> <p><b>1:Heat/0:Cool:</b> If value 1 is sent via a related object, the air conditioner switches to heat mode.</p> <p><b>0:Heat/1:Cool:</b> If value 1 is sent via a related object, the air conditioner switches to cool mode.</p>	<p><b>Disabled</b></p> <p>1:Heat/0:Cool</p> <p>0:Heat/1:Cool</p>
<b>Operating mode +/- object (1-bit)</b>	<p>This parameter is used to enable or disable the operating mode +/- object.</p> <p><b>1:Increase/0:Decrease:</b> If the value 1 is sent, the modes switch according to the following sequence Auto-&gt;Heat-&gt;Cool-&gt;Fan-&gt;Dry</p> <p><b>0:Up/1:Down:</b> If the value 0 is sent, the modes switch according to the following sequence Auto-&gt;Heat-&gt;Cool-&gt;Fan-&gt;Dry</p>	<p><b>Disabled</b></p> <p>1:Increase/0:Decrease</p> <p>0:Up/1:Down</p>
<b>Operating mode individual objects (1-bit)</b>	<p>This parameter is used to enable the operating modes' individual objects. These objects are:</p> <ul style="list-style-type: none"> <li>-&gt;Individual Mode Heat</li> <li>-&gt;Individual Mode Cool</li> <li>-&gt;Individual Mode Auto</li> <li>-&gt;Individual Mode Fan</li> <li>-&gt;Individual Mode Dry</li> </ul>	<p><b>Disabled</b></p> <p>Enabled</p>
<b>Operating mode object (1-byte)</b>	<p>This parameter is used to enable or disable operating mode objects. Via this object, if the specified values are sent to the corresponding mode the operating mode is switched to that mode.</p>	<p><b>Disabled</b></p> <p>Enabled</p>
<b>Operating mode percent value objects</b>	<p>This parameter is used to enable the percent value objects of heating mode and cooling mode.</p>	<p><b>Disabled</b></p> <p>Enabled</p>
<b>&gt; Priority to "Operating mode Heat/Cool"</b>	<p>This parameter is used to enable or disable the giving priority to operating mode Heat/Cool.</p>	<p><b>Disabled</b></p> <p>Enabled</p>

<b>Feedback operating mode individual objects (1-bit)</b>	This parameter is used to enable or disable the feedback objects of individual operating mode objects. If this parameter is enabled, all of the individual feedback objects of operating modes are visible.	<b>Disabled</b> Enabled
<b>Feedback operating mode object (1-byte)</b>	This parameter is used to enable or disable the 1-byte feedback object of the operating mode. According to special values, the operating mode can be easily detected.	<b>Disabled</b> Enabled
<b>Feedback operating mode text object (14-char)</b>	This parameter is used to enable or disable the feedback operating text mode objects.	<b>Disabled</b> Enabled
<b>-&gt; Text for mode AUTO</b>	This parameter is used to type a special name for the operating mode AUTO feedback text object.	-
<b>-&gt; Text for mode HEAT</b>	This parameter is used to type a special name for the operating mode HEAT feedback text object.	-
<b>-&gt; Text for mode COOL</b>	This parameter is used to type a special name for the operating mode COOL feedback text object.	-
<b>-&gt; Text for mode FAN</b>	This parameter is used to type a special name for the operating mode FAN feedback text object.	-
<b>-&gt; Text for mode DRY</b>	This parameter is used to type a special name for the operating mode DRY feedback text object.	-
<b>Energy Saver</b>		
<b>Energy Saver mode</b>	This parameter is used to enable or disable the energy saver mode.	<b>Disabled</b> Enabled
<b>&gt; Polarity</b>	This parameter is used to specify the polarity of the energy saver mode for enabling it according to this configuration.  <b>1:Start/0:Stop:</b> If the value 1 is sent, energy saver mode will be started.  <b>0:Start/1:Stop:</b> If the value 0 is sent, energy saver mode will be started.	<b>1:Start/0:Stop</b> <b>0:Start/1:Stop</b>

<p>&gt; <b>Timer</b></p>	<p>This parameter is used to set a timer for energy saver mode with a 1-byte value.</p> <p><b>Via parameter:</b> Timer interval value will be set via this parameter page.</p> <p><b>Via communication object:</b> Timer interval value will be set via a communication object.</p>	<p><b>Disabled</b></p> <p>Via parameter</p> <p>Via communication object</p>
<p>&gt; <b>Interval (min)</b></p>	<p>This parameter is used to specify the timer interval value via parameter.</p>	<p>0...255</p>
<p>&gt; <b>Setpoint</b></p>	<p>This parameter is used to select the setpoint shifting method.</p> <p><b>Via parameter:</b> The setpoint will be determined according to the parameter value</p> <p><b>Via communication object:</b> The setpoint will be determined via communication object value.</p>	<p><b>Via parameter</b></p> <p>Via communication object</p>
<p>&gt; <b>Value (°C)</b></p>	<p>This parameter is used to specify the setpoint shifting value via parameter.</p>	<p>1...4</p>
<p>&gt; <b>Fan speed</b></p>	<p>This parameter is used to specify the fan speed value when the air conditioner switches to energy saver mode.</p>	<p><b>Via parameter</b></p> <p>Via communication object</p>
<p>&gt; <b>Value (fan)</b></p>	<p>This parameter is used to select the fan speed levels from the parameter list.</p>	<p><b>No change</b></p> <p>Auto</p> <p>Fan 1</p> <p>Fan 2</p> <p>Fan 3</p> <p>Fan 4</p>
<p><b>Power Saver</b></p>		
<p><b>Power Saver mode</b></p>	<p>This parameter is used to enable or disable the power saver mode.</p>	<p><b>Disabled</b></p> <p>Enabled</p>
<p>&gt; <b>Polarity</b></p>	<p>This parameter is used to specify the polarity of the power saver mode for enabling it according to this configuration.</p> <p><b>1:Start/0:Stop:</b> If the value 1 is sent, power saver mode will be started.</p> <p><b>0:Start/1:Stop:</b> If the value 0 is sent, power saver mode will be started.</p>	<p><b>1:Start/0:Stop</b></p> <p>0:Start/1:Stop</p>

<p>&gt; <b>Timer</b></p>	<p>This parameter is used to set a timer for power saver mode with a 1-byte value.</p> <p><b>Via parameter:</b> Timer interval value will be set via this parameter page.</p> <p><b>Via communication object:</b> Timer interval value will be set via a communication object.</p>	<p><b>Disabled</b></p> <p>Via parameter</p> <p>Via communication object</p>
<p>&gt; <b>Interval (min)</b></p>	<p>This parameter is used to specify the timer interval value via parameter.</p>	<p>0...255</p>
<p>&gt; <b>Setpoint</b></p>	<p>This parameter is used to select the setpoint shifting method.</p> <p><b>Via parameter:</b> The setpoint will be determined according to the parameter value</p> <p><b>Via communication object:</b> The setpoint will be determined via communication object value.</p>	<p><b>Via parameter</b></p> <p>Via communication object</p>
<p>&gt; <b>Value (°C)</b></p>	<p>This parameter is used to specify the setpoint shifting value via parameter.</p>	<p>1...4</p>
<p>&gt; <b>Fan speed</b></p>	<p>This parameter is used to specify the fan speed value when the air conditioner switches to power saver mode.</p>	<p><b>Via parameter</b></p> <p>Via communication object</p>
<p>&gt; <b>Value (fan)</b></p>	<p>This parameter is used to select the fan speed levels from the parameter list.</p>	<p><b>No change</b></p> <p>Auto</p> <p>Fan 1</p> <p>Fan 2</p> <p>Fan 3</p> <p>Fan 4</p>
<p><b>Winter</b></p>		
<p><b>Winter mode</b></p>	<p>This parameter is used to enable or disable the winter mode.</p>	<p><b>Disabled</b></p> <p>Enabled</p>
<p>&gt; <b>Polarity</b></p>	<p>This parameter is used to specify the polarity of the winter mode for enabling it according to this configuration.</p> <p><b>1:Start/0:Stop:</b> If the value 1 is sent, winter mode will be started.</p> <p><b>0:Start/1:Stop:</b> If the value 0 is sent, winter mode will be started.</p>	<p><b>1:Start/0:Stop</b></p> <p>0:Start/1:Stop</p>

<p>&gt; <b>Timer</b></p>	<p>This parameter is used to set a timer for winter mode with a 1-byte value.</p> <p><b>Via parameter:</b> Timer interval value will be set via this parameter page.</p> <p><b>Via communication object:</b> Timer interval value will be set via a communication object.</p>	<p><b>Disabled</b></p> <p>Via parameter</p> <p>Via communication object</p>
<p>&gt; <b>Interval (min)</b></p>	<p>This parameter is used to specify the timer interval value via parameter.</p>	<p><b>0...255</b></p>
<p>&gt; <b>Setpoint shifting</b></p>	<p>This parameter is used to select the setpoint shifting method.</p> <p><b>Via parameter:</b> The setpoint will be shifted according to the parameter value</p> <p><b>Via communication object:</b> The setpoint will be shifted via communication object value.</p>	<p><b>Via parameter</b></p> <p>Via communication object</p>
<p>&gt; <b>Value (°C)</b></p>	<p>This parameter is used to specify the setpoint shifting value via parameter.</p>	<p><b>16...18...30</b></p>
<p>&gt; <b>Fan speed</b></p>	<p>This parameter is used to specify the fan speed value when the air conditioner switches to winter mode.</p>	<p><b>Via parameter</b></p> <p>Via communication object</p>
<p>&gt; <b>Value (fan)</b></p>	<p>This parameter is used to select the fan speed levels from the parameter list.</p>	<p><b>No change</b></p> <p>Auto</p> <p>Fan 1</p> <p>Fan 2</p> <p>Fan 3</p> <p>Fan 4</p>
<p><b>Summer</b></p>		
<p><b>Summer mode</b></p>	<p>This parameter is used to enable or disable the summer mode.</p>	<p><b>Disabled</b></p> <p>Enabled</p>
<p>&gt; <b>Polarity</b></p>	<p>This parameter is used to specify the polarity of the summer mode for enabling it according to this configuration.</p> <p><b>1:Start/0:Stop:</b> If the value 1 is sent, summer mode will be started.</p> <p><b>0:Start/1:Stop:</b> If the value 0 is sent, summer mode will be started.</p>	<p><b>1:Start/0:Stop</b></p> <p><b>0:Start/1:Stop</b></p>

<p>&gt; <b>Timer</b></p>	<p>This parameter is used to set a timer for summer mode with a 1-byte value.</p> <p><b>Via parameter:</b> Timer interval value will be set via this parameter page.</p> <p><b>Via communication object:</b> Timer interval value will be set via a communication object.</p>	<p><b>Disabled</b></p> <p>Via parameter</p> <p>Via communication object</p>
<p>&gt; <b>Interval (min)</b></p>	<p>This parameter is used to specify the timer interval value via parameter.</p>	<p><b>0...255</b></p>
<p>&gt; <b>Setpoint shifting</b></p>	<p>This parameter is used to select the setpoint shifting method.</p> <p><b>Via parameter:</b> The setpoint will be shifted according to the parameter value</p> <p><b>Via communication object:</b> The setpoint will be shifted via communication object value.</p>	<p><b>Via parameter</b></p> <p>Via communication object</p>
<p>&gt; <b>Value (°C)</b></p>	<p>This parameter is used to specify the setpoint shifting value via parameter.</p>	<p>16...<b>18</b>...30</p>
<p>&gt; <b>Fan speed</b></p>	<p>This parameter is used to specify the fan speed value when the air conditioner switches to summer mode.</p>	<p><b>Via parameter</b></p> <p>Via communication object</p>
<p>&gt; <b>Value (fan)</b></p>	<p>This parameter is used to select the fan speed levels from the parameter list.</p>	<p><b>No change</b></p> <p>Auto</p> <p>Fan 1</p> <p>Fan 2</p> <p>Fan 3</p> <p>Fan 4</p>

### 3.5. Fan

In this parameter page, the parameter “Fan mode available” defines if the fan mode is available in the indoor unit. If this parameter is set to “No”, all the fan parameters and objects are hidden. All the parameters in this section are related to the Fan Speed properties and communication objects.

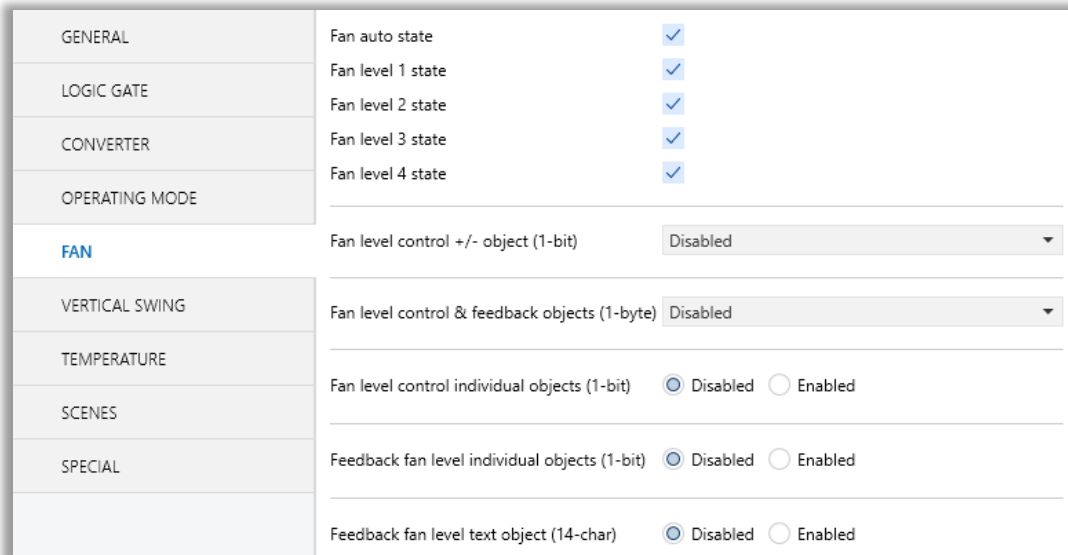

Fig. 42: Fan Configuration Parameter Page

Once the fan mode is enabled, the number of available fan levels in the indoor unit should be defined via the parameter “Number of fan level”. Besides the parameter “AUTO fan mode available” defines if the AUTO fan mode is available in the indoor unit.

**Fan Speed Enumerated/Scaling:** The fan speed can be driven by "numbered or scaled object," selectable by the parameter "Fan level control & feedback objects (1 byte)".

Fan speed Enumerated object can control fan speed of air conditioner via 1 byte object.

FAN SPEED	VALUE
FAN AUTO	0
FAN 1	1
FAN 2	2
FAN 3	3
FAN 4	4

Table 3: Fan Speed - Enumarated Value Table

Fan Speed Scaling object can control the fan speed of the air conditioner according to the value range of predefined parameters.

Example:

If “Fan Speed Scaling” communication object value has given 18%, fan level set to Fan speed 1

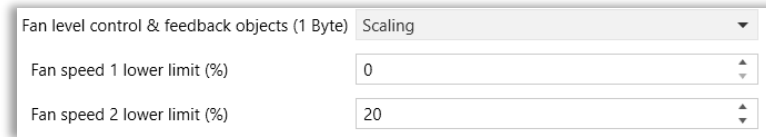

Fig. 13: Fan Speed Scaling Configuration

- **Fan Speed Individual objects (1-bit):** The fan speed of the air conditioner can be selected as the speed auto to 7 with this 1-bit object. When the "Fan Speed Auto Control" object is deactivated, fan speed returns to the previous position before activated that object.
- **Fan Speed +/- object:** Using this object 8 different fan speeds can be selected. The selection can be made with 1-bit values. Switching between the fan speed depends to selected parameters.

\*If the "Loop the sequence" parameter is enabled, the loop changes according to the state of the "Include AUTO fan mode in the sequence" parameter. If the " Include AUTO fan mode in the sequence " parameter is enabled, the increment after Fan speed 5 sets the fan speed level to AUTO. Subsequent increments continue arithmetically.

Special Notes



If a value greater than 4 is received, this data will be accepted and the fan will set at the maximum speed.

Special Notes



Any modification on all above objects will be advised in the following feedback objects:  
 Fan Speed Enumerated Feedback  
 Fan Speed Auto Feedback  
 Fan Speed X Feedback,  
 Fan Speed Text Feedback  
 \*X: 1/2/3/4

### 3.5.1. Parameters List

PARAMETERS	DESCRIPTION	VALUES
------------	-------------	--------

<b>Fan auto state</b>	This parameter is used to enable the AUTO fan mode to be activated.	<b>Unchecked</b> Checked
<b>Fan level X state</b>	This parameter is used to enable the fan level X state to be activated	<b>Unchecked</b> Checked
<b>Fan level control +/- object (1-bit)</b>	This parameter is used to enable or disable the fan level control +/- object.  <b>1:Increase/0:Decrease:</b> If the value 1 is sent, the fan levels switch according to the following sequence Auto->Fan Level 1-> Fan Level 2->...->Fan Level 4  <b>0:Up/1:Down:</b> If the value 1 is sent, the fan levels switch according to the following sequence Fan Level 4->...-> Fan Level 2->Fan Level 1->Auto	<b>Disabled</b> 0:Up/1:Down 1:Increase/0:Decrease
<b>&gt; Loop the sequence</b>	This parameter is used to enable or disable the fan level sequence repeating considering the selected parameter polarity.	<b>No</b> Yes
<b>Fan level control &amp; control feedback objects (1-byte)</b>	This parameter is used to determine the fan level control type with 1-byte communication objects  <b>Scaling:</b> Via scaling object, according to the threshold defined in parameters fan speed will be determined.  <b>Enumerated:</b> Via enumerated object, if value 1 is sent fan level will be fan speed 1. Likewise, value 2 causes fan speed 2 and value 3 causes fan speed 3.	<b>Disabled</b> Scaling Enumerated
<b>&gt; Fan 1 lower limit (%)</b>	This parameter is used to set the lower limit 1 fan level threshold value to compare with the received value from the KNX bus line. After comparison, the corresponding fan speed will be chosen.	<b>0...100</b>
<b>&gt; Fan 2 lower limit (%)</b>	This parameter is used to set the lower limit 2 fan level threshold value to compare with the received value from the KNX bus line. After comparison, the corresponding fan speed will be chosen.	<b>0...20...100</b>
<b>&gt; Fan 3 lower limit (%)</b>	This parameter is used to set the lower limit 3 fan level threshold value to compare with the received value from the KNX bus line. After comparison, the corresponding fan speed will be chosen.	<b>0...40...100</b>
<b>&gt; Fan 4 lower limit (%)</b>	This parameter is used to set the lower limit 4 fan level threshold value to compare with the received value from the KNX bus line. After comparison, the corresponding fan speed will be chosen.	<b>0...60...100</b>

<b>Fan level individual objects (1-bit)</b>	This parameter is used to enable or disable the individual fan level objects.	<b>Disabled</b> Enabled
<b>Feedback fan level text object (14-char)</b>	This parameter is used to enable or disable the feedback fan level text object.	<b>Disabled</b> Enabled
<b>-&gt; Text for mode AUTO</b>	This parameter is used to type a special name for AUTO mode.	-
<b>-&gt; Text for fan speed 1</b>	This parameter is used to type a special name for fan speed 1.	-
<b>-&gt; Text for fan speed 2</b>	This parameter is used to type a special name for fan speed 2.	-
<b>-&gt; Text for fan speed 3</b>	This parameter is used to type a special name for fan speed 3.	-
<b>-&gt; Text for fan speed 4</b>	This parameter is used to type a special name for fan speed 4.	-

### 3.6. Vertical Swing

On this parameter page, all the parameters are related to the Vertical swing properties and communication objects. The parameter “Vertical swing control available” defines if the vanes control is available in the indoor unit. If this parameter is set to “No”, all the fan parameters and objects are hidden.

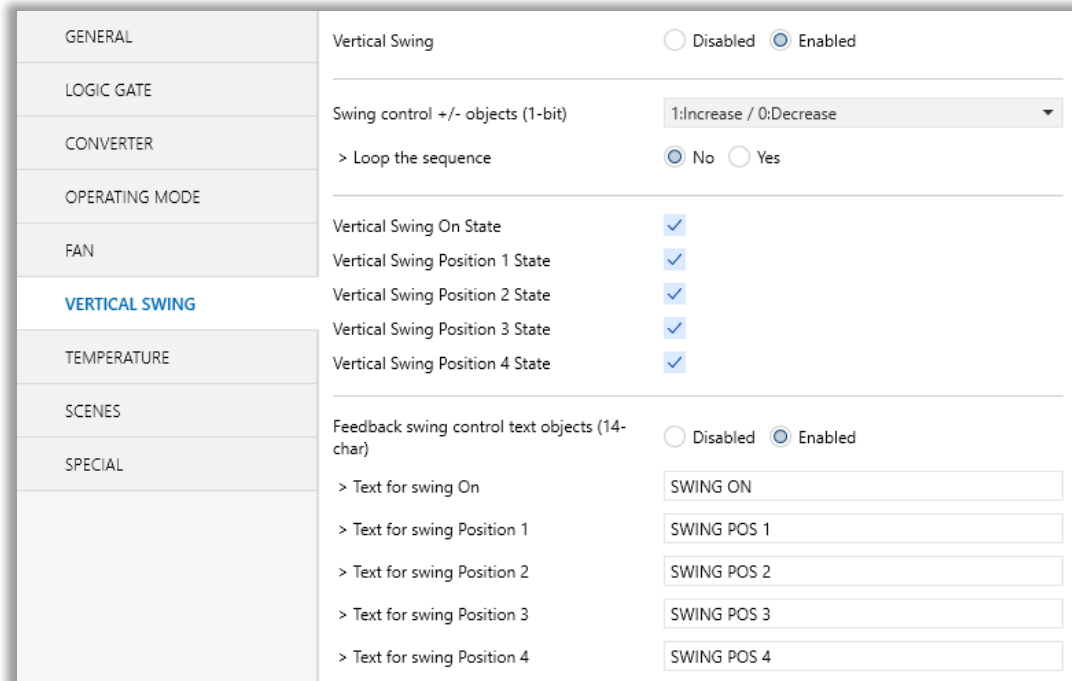

Fig. 14: Vertical Swing Configuration Parameter Page

Once the vertical swing control is enabled, the number of available positions in the indoor unit should be defined via the parameter “Available vertical swing positions”.

**Vertical Swing Control:**

The vertical swing position can be set via some different methods:

- Vertical Swing position can be controlled by sending 1-bit values. While using this method the following sequence is applied:

Loop the sequence: Yes	Loop the sequence: No
------------------------	-----------------------

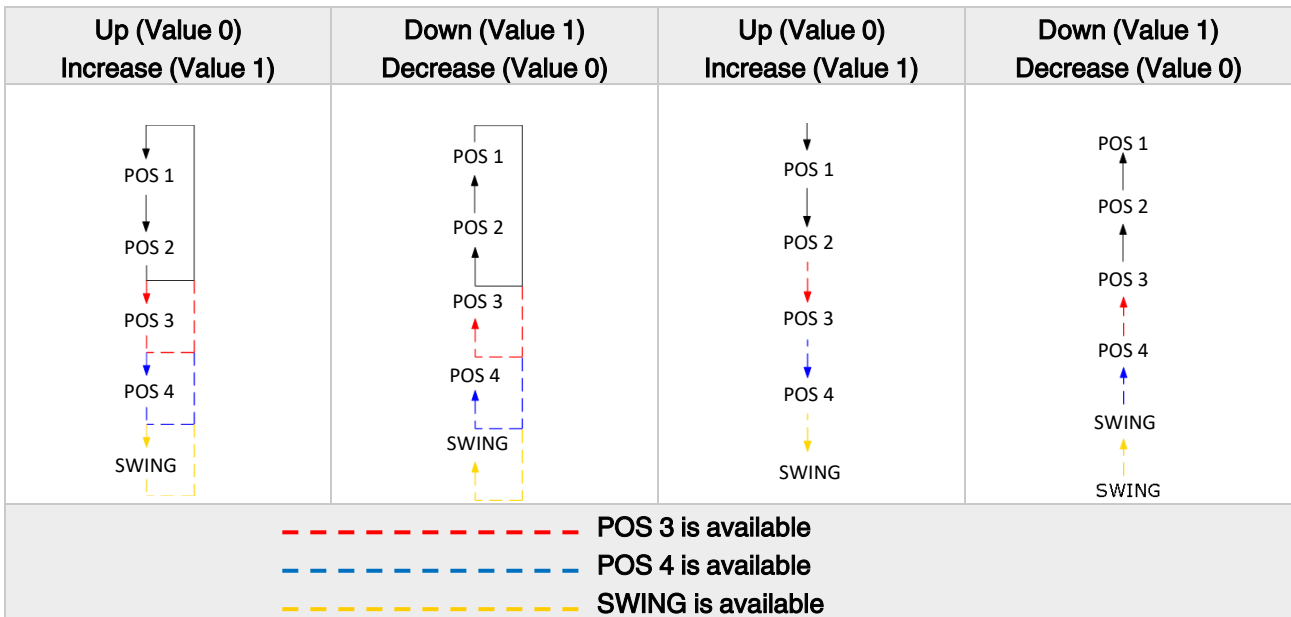

- Vertical swing positions can be controlled via percentage values. The thresholding values for each position are set in the parameters “Vertical swing position (1, 2, 3, 4) lower limit”.
- Vertical swing positions can be controlled by sending the numbers of each position: 1, 2, 3 or 4.

**Special Notes**



If a value greater than 4 or the value 0 is received, this data will be discarded and the vertical swing will remain in the current position.

**Special Notes**



Any modification on all above objects will be advised in the following feedback objects: Swing Position Feedback, Feedback Vertical Swing Text.

**3.6.1. Parameters List**

PARAMETERS	DESCRIPTION	VALUES
Vertical Swing	This parameter is used to enable or disable the vanes control function. If this parameter is selected as Enabled, all of the vertical swing parameters will be visible.	Disabled Enabled

<p><b>Swing control +/- objects (1-bit)</b></p>	<p>This parameter is used to enable the swing control object to change the desired vane position.</p> <p><b>1:Increase/0:Decrease:</b> If the value 1 is sent, the vane position switches according to the following sequence Swing-&gt;Pos 1-&gt;Pos 2-&gt;Pos 3-&gt;Pos 4.</p> <p><b>0:Up/1:Down:</b> If the value 1 is sent, the vane position switches according to the following sequence Swing-&gt;Pos 1-&gt;Pos 2-&gt;Pos 3-&gt;Pos 4.</p>	<p><b>Disabled</b></p> <p>1:Increase/0:Decrease 0:Up/1:Down</p>
<p>&gt; <b>Loop the sequence</b></p>	<p>This parameter is used to control the sequence in a loop. According to vanes position +/- object configuration polarity, the sequence will be repeated.</p>	<p><b>No</b></p> <p>Yes</p>
<p><b>Vertical Swing On State</b></p>	<p>This parameter is used to enable the swing on state to be activated.</p>	<p><b>Unchecked</b></p> <p>Checked</p>
<p><b>Vertical Swing Position X State</b></p>	<p>This parameter is used to enable the swing position X state to be activated</p>	<p><b>Unchecked</b></p> <p>Checked</p>
<p><b>Feedback swing control text objects (14-char)</b></p>	<p>This parameter is used to enable or disable the feedback swing position text object.</p>	<p><b>Disabled</b></p> <p>Enabled</p>
<p>&gt; <b>Text for Swing On</b></p>	<p>This parameter is used to type a special name for the Swing function.</p>	<p><b>SWING</b></p>
<p>&gt; <b>Text for swing Position 1</b></p>	<p>This parameter is used to type a special name for swing position 1.</p>	<p><b>POSITION 1</b></p>
<p>&gt; <b>Text for swing Position 2</b></p>	<p>This parameter is used to type a special name for swing position 2.</p>	<p><b>POSITION 2</b></p>
<p>&gt; <b>Text for vanes Position 3</b></p>	<p>This parameter is used to type a special name for swing position 3.</p>	<p><b>POSITION 3</b></p>
<p>&gt; <b>Text for vanes Position 4</b></p>	<p>This parameter is used to type a special name for swing position 4</p>	<p><b>POSITION 4</b></p>

### 3.7. Temperature

In this section, all of the parameters are corresponding to the setpoint temperature, AC unit ambient temperature. Some parameters of related objects and their tasks are described in this part.

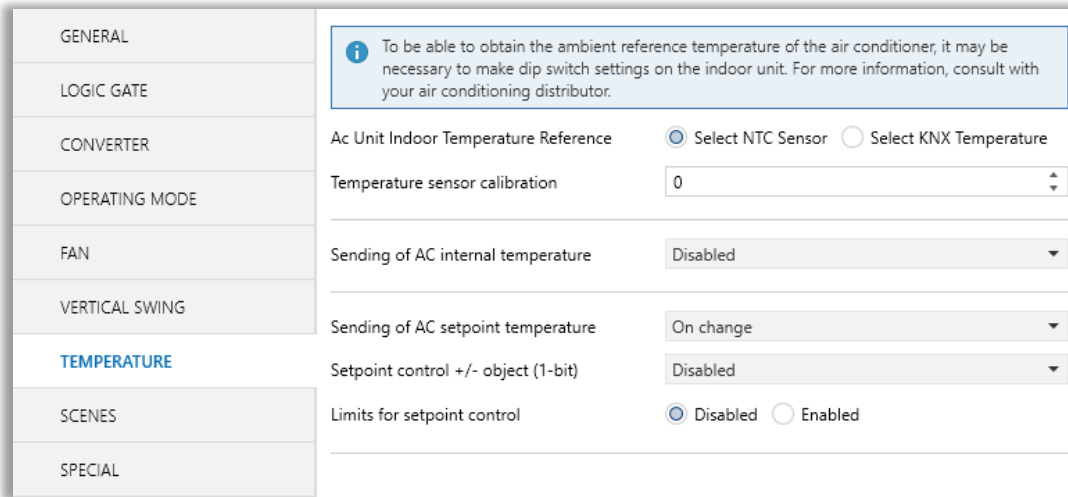

Fig. 15: Temperature Configuration Parameter Page

**Ambient Temperature:**

The air conditioner internal unit can display the temperature information via the "Feedback Indoor Temperature" object. However, it is also possible to receive the measurement of the measured ambient temperature from KNX by enabling the parameter "Ambient temperature received from KNX".

**AC Unit Indoor Temperature Reference:**

Temperature to be taken as the basis for air conditioning; Indoor Temperature sending disabled, Indoor Temperature from KNX, Indoor Temperature Average of KNX and AC Unit, can be selected.

**Special Notes**



The values of the air condition internal temperature and setpoint can be sent to the bus on change and/or periodically. By choosing periodically the period of sending can be defined from 1 to 255 seconds.

## ***Setpoint Temperature:***

Via the parameter “Limits for setpoint control,” it is possible to enable a range for the setpoint to be modified. By enabling this option, the minimum and maximum setpoints available to send via KNX will be defined in the parameters “Setpoint lower limit” and “Setpoint higher limit”. By disabling this option, per default, the lower and higher limits will be limits of the air condition unit.

Via the object “Setpoint Temperature -/+” the setpoint temperature can be modified via a 1-bit object as follow:

- By sending “Up” (Value 0) or “Increase” (Value 1): The setpoint temperature will be increased by steps of 1°C until air condition unit limit or defined higher limit value.
- By sending “Down” (Value 1) or “Decrease” (Value 0): The setpoint temperature will be decreased by steps of 1°C until the air condition unit lower the limit value.

In the following figure, the Temperature configuration parameter page is shown.

### 3.7.1. Parameters List

PARAMETERS	DESCRIPTION	VALUES
AC Unit Indoor Temperature Reference	<p>This parameter is used to determine the temperature source for measuring the ambient temperature.</p> <p><b>Select NTC Sensor:</b> A/C return temperature selected.</p> <p><b>Select KNX sensor:</b> Temperature supplied from KNX.</p>	<p><b>Select NTC Sensor</b></p> <p>Select KNX Sensor</p>
Temperature sensor calibration	<p>This parameter is used to determine the calibration value of the temperature sensor.</p> <p>E.g., the Measured value is 26 °C, and the calibration value is selected as -3.</p> <p>The calibrated value is <math>26 - (3) = 23</math> °C</p>	
Sending of AC internal temperature	<p>This parameter enables the sending of internal temperature value information.</p> <p><b>Disabled:</b> Temperature information is not sent.</p> <p><b>Periodically:</b> Temperature information is sent periodically.</p> <p><b>On change:</b> Temperature information is sent when there is a 1K change in the temperature value.</p> <p><b>Periodically and on change:</b> Temperature information is sent periodically and this information is sent when there is a 0.5K change in the temperature value.</p>	<p><b>Disabled</b></p> <p>Periodically</p> <p>On change</p> <p>Periodically and on change</p>
> Period of sending (sec)	<p>This parameter sets the sending period of the internal temperature value in seconds.</p>	<p>1...255</p>
Sending of AC setpoint temperature	<p>This parameter enables the sending of internal temperature value information.</p> <p><b>Periodically:</b> Temperature information is sent periodically.</p> <p><b>On change:</b> Temperature information is sent when there is a 1K change in the temperature value.</p> <p><b>Periodically and on change:</b> Temperature information is sent periodically and this</p>	<p><b>Periodically</b></p> <p>On change</p> <p>Periodically and on change</p>

	information is sent when there is a 1K change in the temperature value.	
> <b>Period of sending (sec)</b>	This parameter sets the sending period of the setpoint temperature value in seconds.	1...255
<b>Setpoint control +/- object (1-bit)</b>	This parameter enables to change of the desired temperature value as +/- with the 1-bit object.	<b>Disabled</b> 1:Increase/0:Decrease 0:Up/1:down
<b>Limits for setpoint control</b>	This parameter enables limits for the setpoint temperature value.	<b>Disabled</b> Enabled
> <b>Setpoint lower limit</b>	This parameter activates a lower limit for the setpoint temperature value.	16... <b>18</b> ...30
> <b>Setpoint higher limit</b>	This parameter activates a higher limit for the setpoint temperature value.	16... <b>18</b> ...30

### 3.8. Scenes

On this parameter page, up to 5 different scenarios can be configured. Each scene functions are identical and the configuration of each scene permits:

- The number of scenes (Between 1-64) can be assigned.
- The air condition unit's on/off values can be set.
- The air condition unit's AC mode can be configured.
- Fan levels of the related scene can be specified.
- Vane positions of the related scene can be specified.
- The setpoint temperature can be set of the scene.
- The scene can be stored by enabling the storage function.
- Delay time can be specified for starting the scene.

GENERAL	SCENE 1	<input type="radio"/> Disabled <input checked="" type="radio"/> Enabled
LOGIC GATE	> Number	1
CONVERTER	> AC On/Off	On
OPERATING MODE	> AC Mode	Auto
FAN	> AC Fan level	Fan Auto
VERTICAL SWING	> AC Vertical Swing position	Not Involved
TEMPERATURE	> AC Setpoint temperature	Not Involved
	> Storage function	<input checked="" type="radio"/> Disabled <input type="radio"/> Enabled
	> Delay	00:00 mm:ss
SCENES	> Activation object (1-bit)	<input checked="" type="radio"/> Disabled <input type="radio"/> Enabled
SPECIAL	SCENE 2	<input checked="" type="radio"/> Disabled <input type="radio"/> Enabled
	SCENE 3	<input checked="" type="radio"/> Disabled <input type="radio"/> Enabled
	SCENE 4	<input checked="" type="radio"/> Disabled <input type="radio"/> Enabled
	SCENE 5	<input checked="" type="radio"/> Disabled <input type="radio"/> Enabled

Fig. 16: Scenes Configuration Parameter Page

Via the object "Scene", telegrams that contains the call or store functions of a scene are sent. Up to 1...64 scenario numbers can be selected for 5 scenarios via a single group address. The scenario number telegram must match the pre-configured scenario number in the parameters.

The scene number (1-64), is used to recall the scene via the corresponding object. For storage of the scene, the value sent via the object "Scene" must be 128+scene number. The recall of each scene can be delayed whether a time delay has been previously defined in the parameter window.

#### Special Notes



After ETS programming, the scene values parameterized for the output concerned will be overwritten into the gateway. It means that any change made by the user will be deleted. Therefore, it is important, before any maintenance, to know the previous scene configuration and whether the user wants to keep operating with that configuration.

## 3.8.1. Parameters List

PARAMETERS	DESCRIPTION	VALUES
Scene 1 . . Scene 5	This parameter is used to enable or disable the related scenario.	<b>Disabled</b> Enabled
> Number	This parameter is used to specify the scene number of the corresponding scene.	1...64
> AC On/Off	This parameter is used to determine the on/off status of the air condition unit for the selected scenario.	<b>On</b> Off Not Involved
> AC Mode	This parameter is used to specify the mode of the air condition unit for the selected scenario.	<b>Auto</b> Heat Cool Fan Dry Not Involved
> AC Fan level	This parameter is used to specify the fan level of the air condition unit for the selected scenario.	<b>Fan 1</b> Fan 2 Fan 3 Fan 4 Fan Auto Not Involved
> AC Vanes position	This parameter is used to specify the vane positions of the air condition unit for the selected scenario.	Pos 1 <b>Pos 2</b> Pos 3 Pos 4 Swing On Not Involved
> AC Setpoint temperature	This parameter is used to specify the setpoint temperature of the selected scenario.	<b>Not Involved</b> 16°C...30°C
> Storage function	This parameter is used to save the selected scenario.	<b>Disabled</b> Enabled
> Delay (sec)	This parameter is used to set a delay time for starting the selected scene.	0...255
> Activation object (1-bit)	This parameter is used to enable or disable the activation object to activate the scenario.	<b>Disabled</b> Enabled

### 3.9. Special

In this section, special functionalities of the Mitsubishi Electric AC - KNX Gateway are described. The gateway has 4 different functions for special purposes. Each of them is explained in separate subtitles.

GENERAL	Working hours counter	<input type="radio"/> Disabled <input checked="" type="radio"/> Enabled
LOGIC GATE	> Setpoint for alert	<input type="text" value="0-01"/> d-hh
CONVERTER	Enable window contact	<input type="text" value="0:Open / 1:Close"/> ▾
OPERATING MODE	> Switch-off time delay	<input checked="" type="radio"/> Via parameter <input type="radio"/> Via communication object
FAN	> Switch-off time delay	<input type="text" value="00:00"/> hh:mm
VERTICAL SWING	> Reject On/Off actions if window is open	<input checked="" type="radio"/> Disabled <input type="radio"/> Enabled
TEMPERATURE	> Behavior after window is close	<input type="text" value="No reaction - Last state"/> ▾
SCENES	Enable standby function	<input type="text" value="1:Occupied / 0:Not occupied"/> ▾
<b>SPECIAL</b>	> Standby function delay	<input checked="" type="radio"/> Via parameter <input type="radio"/> Via communication object
	> Standby function delay	<input type="text" value="00:00"/> hh:mm
	> Behavior during standby function	<input type="text" value="Setpoint shifting"/> ▾
	> Setpoint shifting	<input checked="" type="radio"/> Via parameter <input type="radio"/> Via communication object
	> Setpoint shifting (°C)	<input type="text" value="1"/> ▲ ▾
	> Activate secondary standby action	<input checked="" type="radio"/> Disabled <input type="radio"/> Enabled
	> Reject modifications during standby function	<input checked="" type="radio"/> Disabled <input type="radio"/> Enabled
	> Behavior after standby function	<input type="text" value="No reaction - Last state"/> ▾
	Enable timer function	<input type="radio"/> Disabled <input checked="" type="radio"/> Enabled
	> Polarity	<input checked="" type="radio"/> 1:Start / 0:Stop <input type="radio"/> 0:Start / 1:Stop
	> Timer duration	<input checked="" type="radio"/> Via parameter <input type="radio"/> Via communication object
	> Timer duration	<input type="text" value="1"/> ▲ ▾ Minutes
	> Timer retriggerable	<input checked="" type="radio"/> No <input type="radio"/> Yes

Fig. 17: Special Configuration Parameter Page

**Working Hours Counter:** This function is used to know the air conditioner's operating hour as "ON" position. When the "ON" status of the air condition unit is counted for one hour, the object value increases "1K". The counter is available to create an alert to warn the user after the desired time later. The counter can be reset via the "Reset Hours Counter" object.

**Window Contact:** This function is used for window contacts to determine the operation type when the window contacts are open or close. When the "window is open" information is received, it is possible to switch off the air condition unit or activate any predefined scene. However, it is possible to specify a delay time for the operation type to be started or to restrict the On / Off action of the air condition unit. After incoming "window contacts are closed" information, the behaviour of the air condition unit can be selected as one of the predefined scenarios, OFF or the previous state of this function.

**Standby Function:** This function is used to activate the standby modes for the air condition unit to determine the operation type for the standby modes. During standby function, it is possible to make setpoint shifting, activate any predefined scene or switch off the air condition unit. However, it is possible to specify delay time for operation type to be started or to reject modifications for the air condition unit during standby function. After incoming standby function stop information, the behaviour of the air condition unit can be selected as one of scenario, off or the previous state. Additionally, a secondary standby function is available and the same parameters and object are valid for the secondary standby function.

**Timer Function:** The timer function switches off the air condition unit after a defined time. Polarity and durations can be determined via sub-parameters of this function. The timer function is also retriggerable and when timer retrigger is enabled, the timer restarts itself for counting for switch off the air condition unit.

## 3.9.1. Parameters List

PARAMETERS	DESCRIPTION	VALUES
Working hours counter	This parameter is used to enable or disable the working hours counter function.	Disabled Enabled
> Setpoint for alert (d-hh)	This parameter is used to set a setpoint alarm point for the working hours counter of the air conditioner unit.	0-01...9-23
Enable window contact	This parameter is used to enable or disable the air conditioner unit's window contact function.	Disabled 0:Open/1:Close 1:Open/0:Close
> Switch-off time delay	This parameter is used to specify the switch-off time delay that is sent via parameter or communication object.	Via parameter Via communication object
> Switch-off time delay (hh:mm)	This parameter is used to set delay time in minutes to switch off the air conditioner.	00:00...04:15
> Reject On/Off actions if window is open	This parameter is used to reject on & off actions of the air conditioner unit's when the window is opened.	Disabled Enabled
> Behaviour after window is close	This parameter is used to specify the behaviour after window is closed. For instance, one of the configured scenarios can be operated, the conditioner unit is turned off or the last state is maintained.	No reaction – Last state Off Scene 1 Scene 2 Scene 3 Scene 4 Scene 5
Enable standby function	This parameter is used to enable or disable the standby function. According to occupied or not occupied status, configurations can be made.	Disabled 1:Occupied/0:Not occupied 1:Start/0:Stop
> Standby function delay	This parameter is used to specify the standby function delay that is sent via parameter or communication object.	Via parameter Via communication object

> <b>Standby function delay (hh:mm)</b>	This parameter is used to set a delay time in minutes for the standby function.	00:00...04:15
> <b>Behaviour during standby function</b>	This parameter is used to configure the behaviour during the standby function. For instance, one of the configured scenarios can be operated, the conditioner unit is turned off or the last state is maintained.	<b>Setpoint shifting</b> Off Scene 1 Scene 2 Scene 3 Scene 4 Scene 5
> <b>Setpoint shifting</b>	This parameter is used to specify the setpoint shifting that is sent via parameter or communication object.	<b>Via parameter</b> Via communication object
> <b>Setpoint shifting (°C)</b>	This parameter is used to set the setpoint shifting temperature value.	1...4
> <b>Activate secondary standby action</b>	This parameter is used to enable or disable the secondary standby function.	<b>Disabled</b> Enabled
> <b>Secondary standby action delay</b>	This parameter is used to specify the secondary standby action delay that is sent via parameter or communication object.	<b>Via parameter</b> Via communication object
> <b>Secondary standby action delay (hh:mm)</b>	This parameter is used to specify the secondary standby action delay in minutes.	00:05...04:15
> <b>Behaviour during secondary standby function</b>	This parameter is used to configure the behaviour during the secondary standby function. For instance, one of the configured scenarios can be operated, the conditioner unit is turned off or the last state is maintained.	<b>Setpoint shifting</b> Off Scene 1 Scene 2 Scene 3 Scene 4 Scene 5
> <b>Secondary setpoint shifting</b>	This parameter is used to set the secondary setpoint shifting temperature value.	<b>Via parameter</b> Via communication object
> <b>Secondary setpoint shifting (°C)</b>	This parameter is used to set the secondary setpoint shifting temperature value.	1...4
> <b>Reject modifications during standby function</b>	This parameter is used to enable or disable the reject modifications during the standby function. If this parameter is enabled, no modifications can be allowed in standby mode.	<b>Disabled</b> Enabled

<p>&gt; <b>Behaviour after standby function</b></p>	<p>This parameter is used to configure the behaviour during the standby function. For instance, one of the configured scenarios can be operated, the conditioner unit is turned off or the last state is maintained.</p>	<p><b>No reaction – Last state</b> Off Scene 1 Scene 2 Scene 3 Scene 4 Scene 5</p>
<p><b>Enable timer function</b></p>	<p>This parameter is used to enable or disable the timer function.</p>	<p><b>Disabled</b> Enabled</p>
<p>&gt; <b>Polarity</b></p>	<p>This parameter is used to specify the polarity of enabling command the timer function.</p>	<p><b>1:Start/0:Stop</b> 0:Start/1:Stop</p>
<p>&gt; <b>Timer duration</b></p>	<p>This parameter is used to specify the timer duration that is sent via parameter or communication object.</p>	<p><b>Via parameter</b> Via communication object</p>
<p>&gt; <b>Timer duration (min)</b></p>	<p>This parameter is used to set delay time in minutes for the timer function.</p>	<p>1...65535</p>
<p>&gt; <b>Timer retriggerable</b></p>	<p>This parameter is used to restart the timer.</p>	<p><b>No</b> Yes</p>

## 4. ETS Objects List & Descriptions

The Interra Mitsubishi Electric AC - KNX Gateway can communicate via the KNX bus line. In this section, the group objects of the Interra Mitsubishi Electric Gateway are described.

ETS group objects are divided into 10 main parts, and these are :

- ❖ **General** - General group objects to the Mitsubishi Electric Gateway.
- ❖ **Logic Gate** - These objects are related to logic gate parameters.
- ❖ **Converter** - These objects are related to converter parameters.
- ❖ **Operating Mode** - These objects are related to operating mode parameters.
- ❖ **Fan** - These objects are related to fan parameters.
- ❖ **Vertical Swing** - These objects are related to vertical swing parameters.
- ❖ **Temperature** - These objects are related to temperature parameters.
- ❖ **Scenes**- These objects are related to scenes parameters.
- ❖ **Special** - These objects are related to special functions.

### Special Note



**Due to the flexible ETS configurations feature, some group objects are dynamic and they are only visible if the related parameters are activated in the application program.**

All of the group objects of Interra Mitsubishi Electric AC - KNX Gateway are listed below. You can quickly browse through this table to get the functional capabilities of Interra Mitsubishi Electric Gateway.

The detailed functions of group objects are described in different topics.

No	Name	Function	DTP Type	Length	Flags				
					C	R	W	T	U
1	Alive Beacon	1:True/0:False	1.002	1 bit	X	X		X	
2	Climate On/Off	1:On/0:Off	1.001	1 bit	X		X	X	
3	Feedback Climate On/Off	1:On/0:Off	1.001	1 bit	X	X		X	
4	Operating Mode	0:Auto / 1:Heat / 3:Cool / 9:Fan / 14:Dry	20.105	1 byte	X		X	X	
5	Feedback Operating Mode	0:Auto / 1:Heat / 3:Cool / 9:Fan / 14:Dry	20.105	1 byte	X	X		X	
6	Operating Mode Heat/Cool	1:Heat/0:Cool	1.100	1 bit	X		X	X	
	Operating Mode Cool/Heat	0:Heat/1:Cool	1.100	1 bit	X		X	X	
7	Feedback Operating Mode Heat/Cool	1:Heat/0:Cool	1.100	1 bit	X	X		X	
	Feedback Operating Mode Cool/Heat	0:Heat/1:Cool	1.100	1 bit	X	X		X	
8	Heating Mode Percent Value	0%:Off / 1%-100%:On+Heat	5.001	1 byte	X		X	X	
9	Cooling Mode Percent Value	0%:Off / 1%-100%:On+Cool	5.001	1 byte	X		X	X	
10	Individual Mode Auto	1:Set Mode Auto/0:Nothing	1.002	1 bit	X		X	X	
11	Feedback Individual Mode Auto	1:Auto	1.002	1 bit	X	X		X	
12	Individual Mode Heat	1:Set Mode Heat/0:Nothing	1.002	1 bit	X		X	X	
13	Feedback Individual Mode Heat	1:Heat	1.002	1 bit	X	X		X	
14	Individual Mode Cool	1:Set Mode Cool/0:Nothing	1.002	1 bit	X		X	X	
15	Feedback Individual Mode Cool	1:Cool	1.002	1 bit	X	X		X	
16	Individual Mode Fan	1:Set Mode Fan/0:Nothing	1.002	1 bit	X		X	X	
17	Feedback Individual Mode Fan	1:Fan	1.002	1 bit	X	X		X	
18	Individual Mode Dry	1:Set Mode Dry/0:Nothing	1.002	1 bit	X		X	X	
19	Feedback Individual Mode Dry	1:Dry	1.002	1 bit	X	X		X	
20	Operating Mode +/-	0:Up/1:Down	1.008	1 bit	X		X	X	
		1:Increase/0:Decrease	1.008	1 bit	X		X		
21	Feedback Operating Mode Text	Operating Mode Text	16.001	14 bytes	X	X		X	
22	Fan Speed Percent	Threshold Defined in Parameter	5.001	1 byte	X		X	X	
	Fan Speed Enumerated	0:Auto/1:Speed1...4:Speed4	5.100	1 byte	X		X	X	
23	Feedback Fan Speed	0:Auto/1:Speed1...4:Speed4	5.100	1 byte	X	X		X	
24	Fan Speed Auto/Manual	1:Auto/0:Manual	1.001	1 bit	X		X	X	
25	Feedback Fan Speed Auto/Manual	1:Auto/0:Manual	1.001	1 bit	X	X		X	
26	Individual Fan Speed 1	1:Set Fan Speed1/0:Nothing	1.002	1 bit	X		X	X	

27	Feedback Individual Fan Speed 1	1:Fan Speed 1	1.002	1 bit	X	X		X
28	Individual Fan Speed 2	1:Set Fan Speed 2/0:Nothing	1.002	1 bit	X		X	X
29	Feedback Individual Fan Speed 2	1:Fan Speed 2	1.002	1 bit	X	X		X
30	Individual Fan Speed 3	1:Set Fan Speed 3/0:Nothing	1.002	1 bit	X		X	X
31	Feedback Individual Fan Speed 3	1:Fan Speed 3	1.002	1 bit	X	X		X
32	Individual Fan Speed 4	1:Set Fan Speed 4/0:Nothing	1.002	1 bit	X		X	X
33	Feedback Individual Fan Speed 4	1:Fan Speed 4	1.002	1 bit	X	X		X
34	Fan Speed +/-	1:Increase/0:Decrease	1.008	1 bit	X		X	X
		0:Up/1:Down	1.008	1 bit	X		X	X
35	Feedback Fan Speed Text	Fan Speed Text	16.001	14 bytes	X	X		X
36	Swing Position Control	0 = Swing On, 1 = Pos1, 2 = Pos 2, 3 = Pos 3, 4 = Pos 4		1 byte	X		X	X
37	Swing Position Feedback	0 = Swing On, 1 = Pos1, 2 = Pos 2, 3 = Pos 3, 4 = Pos 4		1 byte	X	X		X
38	Vertical Swing +/-	1:Increase / 0:Decrease	1.008	1 bit	X		X	X
		0:Up / 1:Down	1.008	1 bit	X		X	X
39	Feedback Vertical Swing Text	Vertical Swing Text	16.001	14 bytes	X	X		X
40	Setpoint Temperature	Temperature (Celsius)	9.001	2 bytes	X		X	X
41	Feedback Setpoint Temperature	Temperature (Celsius)	9.001	2 bytes	X	X		X
42	Setpoint Temperature -/+	0:Up/1:Down	1.008	1 bit	X		X	X
		1:Increase/0:Decrease	1.008	1 bit	X		X	X
43	KNX Ambient Temperature	Temperature (Celsius)	9.001	2 bytes	X	X	X	X
44	Analog Thermistor Temperature Feedback	Temperature (Celsius)	9.001	2 bytes	X	X		X
45	Feedback Ambient Temperature	Temperature (Celsius)	9.001	2 bytes	X	X		X
46	Window Contact Status	0:Open/1:Close	1.019	1 bit	X	X	X	X
		1:Open/0:Close	1.019	1 bit	X	X	X	X
47	Window Switch-Off Delay	0-255 min	20.013	1 byte	X		X	X
48	Standby Function	1:Occupied/0:Not Occupied	1.010	1 bit	X		X	X
		1:Start/0:Stop	1.010	1 bit	X		X	X
49	Feedback Stanby Function	1:Occupied/0:Not Occupied	1.010	1 bit	X		X	X
		1:Start/0:Stop	1.010	1 bit	X	X		X
50	Standby Function Delay	0-255 min	20.013	1 byte	X		X	X
51	Stanby Function Setpoint Shifting	Temperature (Celsius)	9.001	2 bytes	X		X	X
52	Stanby Function Secondary Delay	0-255 min	20.013	1 byte	X		X	X
53	Standby Function Secondary Setpoint Shifting	Temperature (Celsius)	9.001	2 bytes	X		X	X

54	Timer Function	0:Start/1:Stop	1.010	1 bit	X		X	X	
		1:Start/0:Stop	1.010	1 bit	X		X	X	
55	Feedback Timer Function	0:Start/1:Stop	1.010	1 bit	X	X		X	
		1:Start/0:Stop	1.010	1 bit	X	X		X	
56	Timer Function	1-65535 min	20.013	1 byte	X		X	X	
57	Energy Saver Mode	0:Start/1:Stop	1.010	1 bit	X		X	X	
		1:Start/0:Stop	1.010	1 bit	X		X	X	
58	Feedback Energy Saver Mode	0:Start/1:Stop	1.010	1 bit	X	X		X	
		1:Start/0:Stop	1.010	1 bit	X	X		X	
59	Energy Saver Mode Timer Duration	0-255 min	20.013	1 byte	X		X	X	
60	Energy Saver Mode Setpoint Shifting	Temperature (Celcius)	9.001	2 bytes	X		X	X	
61	Energy Saver Mode Fan Speed	0:Auto/1:Fan1/2:Fan2/3:Fan3/4:Fan4/5:Fan5	5.100	1 byte	X		X	X	
62	Power Saver Mode	0:Start/1:Stop	1.010	1 bit	X		X	X	
		1:Start/0:Stop	1.010	1 bit	X		X	X	
63	Feedback Power Saver Mode	0:Start/1:Stop	1.010	1 bit	X	X		X	
		1:Start/0:Stop	1.010	1 bit	X	X		X	
64	Power Saver Timer Duration	0-255 min	20.013	1 byte	X		X	X	
65	Power Saver Mode Setpoint Shifting	Temperature (Celcius)	9.001	2 bytes	X		X	X	
66	Power Saver Mode Fan Speed	0:Auto/1:Fan1/2:Fan2/3:Fan3/4:Fan4/5:Fan5	5.100	1 byte	X		X	X	
67	Winter Mode	0:Start/1:Stop	1.010	1 bit	X		X	X	
		1:Start/0:Stop	1.010	1 bit	X		X	X	
68	Feedback Winter Mode	0:Start/1:Stop	1.010	1 bit	X	X		X	
		1:Start/0:Stop	1.010	1 bit	X	X		X	
69	Winter Mode Timer Duration	0-255 min	20.013	1 byte	X		X	X	
70	Winter Mode Setpoint	Temperature (Celcius)	9.001	2 bytes	X		X	X	
71	Winter Mode Fan Speed	0:Auto/1:Fan1/2:Fan2/3:Fan3/4:Fan4/5:Fan5	5.100	1 byte	X		X	X	
72	Summer Mode	0:Start/1:Stop	1.010	1 bit	X		X	X	
		1:Start/0:Stop	1.010	1 bit	X		X	X	
73	Feedback Summer Mode	0:Start/1:Stop	1.010	1 bit	X	X		X	
		1:Start/0:Stop	1.010	1 bit	X	X		X	
74	Summer Mode Timer Duration	0-255 min	20.103	1 byte	X		X	X	
75	Summer Mode Setpoint	Temperature (Celcius)	9.001	2 bytes	X		X	X	
76	Summer Mode Fan Speed	0:Auto/1:Fan1/2:Fan2/3:Fan3/4:Fan4/5:Fan5	5.100	1 byte	X		X	X	
77	Scene	1-64:Run / 128+Scene:Storage	18.001	1 byte	X		X	X	
78	Scene 1 Run	1:Run Scene/0:Nothing	1.002	1 bit	X		X	X	

83	Scene 1 Storage	1:Storage Scene/0:Nothing	1.002	1 bit	X		X	X	
88	Feedback Current Scene	1-64 Current Scene	17.001	1 byte	X	X		X	
89	Device Control Locking	1:Enable/0:Disable	1.003	1 bit	X		X	X	
		0:Enable/1:Disable	1.003	1 bit	X		X	X	
90	Feedback Error Alarm	1:Alarm/0:No Alarm	1.005	1 bit	X	X		X	
91	Feedback Error Code	Error Code Information		2 bytes	X	X		X	
92	Feedback Error Code Text	Error Text Information	16.001	14 bytes	X	X		X	
93	Feedback Working Hours Counter	Working Hours Counter	13.100	4 bytes	X	X		X	
94	Feedback Working Hours Alert	1:Alarm/0:No Alarm	1.005	1 bit	X	X		X	
95	Reset Hours Counter	1:Reset/0:Nothing	1.015	1 bit	X		X	X	
100	Logic 1 – Input 1	Logic Input	1.002	1 bit	X	X	X	X	
104	Logic 1 – Output	Logic Output	1.002	1 bit	X	X		X	
120	Converter 1 – Input (1-Bit)	Converter Input	1.006	1 bit	X	X	X	X	
121	Converter 1 – Input (2-Bit)	Converter Input	2.006	2 bit	X	X	X	X	
122	Converter 1 – Input (1-Byte)	Converter Input	5.010	1 byte	X	X	X	X	
123	Converter 1 – Input (2-Byte)	Converter Input	7.001	2 bytes	X	X	X	X	
124	Converter 1 – Output (1-Bit)	Converter Output	1.006	1 bit	X	X	X	X	
125	Converter 1 – Output (2-Bit)	Converter Output	2.006	2 bit	X	X	X	X	
126	Converter 1 – Output (1-Byte)	Converter Output	5.010	1 byte	X	X	X	X	
127	Converter 1 – Output (2-Byte)	Converter Output – 2 Bytes	7.001	2 bytes	X	X	X	X	

## 4.1. General Objects

This section describes the "general" group objects and their properties. General group objects, as the name suggests, indicate the general characteristics of the Mitsubishi Electric Gateway.

Object Number	Object Name	Function	Type	Flags
1	Alive beacon	1:True/0:False	1 bit	CT

This object is used to monitor the presence of the device on the KNX bus line regularly. However, monitoring telegrams can be sent cyclically on the KNX bus line. This object appears only the "Alive beacon state" parameter is enabled.

DPT: 1.002 (Boolean)

2	Climate On/Off	1:On/0:Off	1 bit	CW
---	----------------	------------	-------	----

This object is used to turn the Gateway on or off. Also, this object is visible permanently. If you associate the desired group address, Gateway can be controlled with On and Off.

DPT: 1.001 (Switch)

3	Feedback Climate On/Off	1:On/0:Off	1 bit	CRT
---	-------------------------	------------	-------	-----

This object is used to check the status of the air conditioner unit. Also, this object is visible permanently. If you associate the desired group address, Gateway's ON and OFF status can be monitored.

DPT: 1.001 (Switch)

89	Device Control Locking	1:Enabled / 0:Disabled 0:Enabled / 1:Disabled	1 bit	CRT
----	------------------------	--	-------	-----

This object is used to lock the gateway device. When a value that predetermined from parameter is sent to this communication object, the gateway is locked. If a value is sent to the gateway via its communication objects, all values are ignored. For unlocking the gateway, a opposite value of determined from parameter must be sent.

DPT: 1.003 (Enable)

90	Feedback Error Alarm	1:Alarm/0:No Alarm	1 bit	CRT
----	----------------------	--------------------	-------	-----

This object is used to check the status of the air conditioner unit's error alarm. Also, this object is visible permanently. If there is an error alarm and a group address is associated with the corresponding object, the alarm can be monitored.

DP: 1.005 (alarm)

<b>91</b>	<b>Feedback Error Code</b>	<b>Error Code Information</b>	<b>2 bytes</b>	<b>CRT</b>
-----------	----------------------------	-------------------------------	----------------	------------

This object is used to give information about the error codes. This functionality allows sending messages to the KNX bus informing about errors. Errors management handles air conditioner unit error codes as well as any communication errors that may arise. For more detailed information check the section APPENDIX.

<b>92</b>	<b>Feedback Error Code Text</b>	<b>Error Text Information</b>	<b>14 bytes</b>	<b>CRT</b>
-----------	---------------------------------	-------------------------------	-----------------	------------

This object is used to give information about the 2 Byte error codes in string format.

DPT: 16.001 (Character String) (ISO 8859-1)

## 4.2. Logic Gate Objects

This section describes the "Logic Gate" group objects and their properties. Logic Gate group objects, as the name suggests, indicate the logical operations that can be made with Mitsubishi Electric Gateway.

Object Number	Object Name	Function	Type	Flags
100, 105, 110, 115 / 101, 106, 111, 116 / 102, 107, 112, 117 / 103, 108, 113, 118	Logic X – Input 1 Logic X – Input 2 Logic X – Input 3 Logic X – Input 4	Logic Input	1 bit	CRWT

This object is used to set the inputs of the logical gate to be used. Logical associations can be made over 1-bit values. The result is obtained according to the type of logical gate selected.

DPT: 1.002 (Boolean)

104, 109, 114, 119	Logic X – Output	Logic Output	1 bit	CRT
-----------------------	------------------	--------------	-------	-----

This object is used to obtain the result of the logical gate to be used. The output value of the logical gate is 1 bit. The result is obtained according to the type of logical gate selected.

DPT: 1.002 (Boolean)

### Special Notes



This is a fully compatible KNX device that must be configured and set up using the standard KNX tool ETS. Up to 4 different logic gates can be selected. Each logic gate can be set independently.

### 4.3. Converter Objects

This section describes the "Converter" group objects and their properties. Converter group objects are used to make mathematical operations and data converting from different types. Up to 8 different converters can be configured.

Object Number	Object Name	Function	Type	Flags
120, 121, 122, 123/ 128, 129, 130 ,131/.... 176, 177, 178, 179	Converter X – Input (1 Bit) Converter X – Input (2 Bits) Converter X – Input (1 Byte) Converter X – Input (2 Bytes)	Converter Input	1 bit 2 bits 1 byte 2 bytes	CRWT

This object is used to set the converter inputs to be used. The conversion processes can be made via 1 bit, 2 bit, 1 byte and 2-byte values. The result is obtained according to the input type of the selected converter.

DPT:

1 Bit (1.006 Binary Value)

2 Bits (2.006 Binary Value)

1 Byte (5.010 Counter Pulses (0...255))

2 Bytes (7.001 Pulses)

124, 125, 126, 127/ 132, 133, 134, 135/ .... 180, 181, 182, 183	Converter X – Output (1 Bit) Converter X – Output (2 Bits) Converter X – Output (1 Byte) Converter X – Output (2 Bytes)	Converter Output	1 bit 2 bits 1 byte 2 bytes	CRWT
---	--	------------------	--------------------------------------	------

This object is used to obtain the result of the converter to be used. The output value of the converter can be 1 bit, 2-bit, 1 byte and 2 bytes. The result is obtained according to the configuration of the selected converter.

DPT:

1 Bit (1.006 Binary Value)

2 Bits (2.006 Binary Value)

1 Byte (5.010 Counter Pulses (0...255))

2 Bytes (7.001 Pulses)

### 4.4. Operating Mode Objects

This section describes the "Operating Mode" group objects and their properties. Heat, cool, dry, auto and fan mode communication objects are described. Also, simple heating-cooling mode and summer, winter, energy saver and power saver mode objects are clarified.

Object Number	Object Name	Function	Type	Flags
4	Operating Mode	0:Auto / 1:Heat / 3:Cool / 9:Fan / 14:Dry	1 byte	CWT

This object is used to set the operating modes of the air conditioner. You can select AUTO with 0, HEAT with 1, COOL with 3, FAN with 9, and DRY with 14.

DPT: 20.105 (HVAC Control Mode)

5	Feedback Operaring Mode	0:Auto / 1:Heat / 3:Cool / 9:Fan / 14:Dry	1 byte	CRT
---	-------------------------	---	--------	-----

This object is used to monitor the status of the operating modes of the air conditioner. With value 0 the status is AUTO, value 1 the status is HEAT, with value 3 status is COOL, with value 9 the status is FAN and with value 14 the status is DRY can be understood.

DPT: 20.105 (HVAC Control Mode)

6	Operating Mode Heat/Cool	1:Heat/0:Cool	1 bit	CWT
	Operating Mode Cool/Heat	0:Heat/1:Cool		

This object is used to set the operating mode of the air conditioner unit. When selecting this option, the related 1-bit object will be enabled. It allows establishing the desired mode: Cool mode, writing the value "0" in the object and Heat mode, writing the value "1" or vice versa.

DPT: 1.100 (Cooling/Heating)

7	Feedback Operating Mode Heat/Cool	0-Cool;1-Heat	1 bit	CRT
	Feedback Operating Mode Cool/Heat	0-Heat;1-Cool		

This object is used to check the operating mode of the air conditioner unit.

DPT: 1.100 (Cooling/Heating )

<b>8</b>	<b>Heating Mode Percent Value</b>	<b>0%:Off/1%-100%:On+Heat</b>	<b>1 byte</b>	<b>CWT</b>
----------	-----------------------------------	-------------------------------	---------------	------------

This object is used to change operating mode to heat via incoming percentage value. It also provides compatibility with KNX thermostats that control the demand for heating or cooling by using percentage values. In these thermostats, the percentage demand is meant to be applied on a fluid valve of the heating/cooling system. If a non-zero value is received (>0%) the indoor unit will switch on to Heat mode.

DPT: 5.001 (Percentage (0..100%))

<b>9</b>	<b>Cooling Mode Percent Value</b>	<b>0%:Off/1%-100%:On+Cool</b>	<b>1 byte</b>	<b>CW</b>
----------	-----------------------------------	-------------------------------	---------------	-----------

This object is used to change operating mode to cool via incoming percentage value. It also provides compatibility with KNX thermostats that control the demand for heating or cooling by using percentage values. In these thermostats, the percentage demand is meant to be applied on a fluid valve of the heating/cooling system. If a non-zero value is received (>0%) the indoor unit will switch on to Cool mode.

DPT: 5.001 (Percentage (0..100%))

<b>10</b>	<b>Individual Mode Auto</b>	<b>1:Set Mode Auto / 0:Nothing</b>	<b>1 bit</b>	<b>CWT</b>
-----------	-----------------------------	--	--------------	------------

This object is used to change the air conditioner's operating mode to auto mode via a 1-bit object individually. If the value 1 is sent over the 1-bit value, the air conditioning unit will switch to auto mode.

DPT: 1.002 (Boolean)

<b>11</b>	<b>Feedback Individual Mode Auto</b>	<b>1:Auto</b>	<b>1 bit</b>	<b>CRT</b>
-----------	--------------------------------------	---------------	--------------	------------

This object is used to monitor the air condition unit status individually. If value 1 is received from this object, the operating mode is auto.

DPT: 1.002 (Boolean)

<b>12</b>	<b>Individual Mode Heat</b>	<b>1:Set Mode Heat / 0:Nothing</b>	<b>1 bit</b>	<b>CWT</b>
-----------	-----------------------------	--	--------------	------------

This object is used to change the air conditioner's operating mode to heat mode via a 1-bit object individually. If the value 1 is sent over the 1-bit value, the air conditioning unit will switch to heat mode.

DPT: 1.002 (Boolean)

<b>13</b>	<b>Feedback Individual Mode Heat</b>	<b>1:Heat</b>	<b>1 bit</b>	<b>CRT</b>
-----------	--------------------------------------	---------------	--------------	------------

This object is used to monitor the air condition unit status individually. If value 1 is received from this object, the operating mode is heating.

DPT: 1.002 (Boolean)

<b>14</b>	<b>Individual Mode Cool</b>	<b>1:Set Mode Cool / 0:Nothing</b>	<b>1 bit</b>	<b>CWT</b>
-----------	-----------------------------	--	--------------	------------

This object is used to change the air conditioner's operating mode to cool mode via a 1-bit object individually. If the value 1 is sent over the 1-bit value, the air conditioning unit will switch to cool mode.

DPT: 1.002 (Boolean)

<b>15</b>	<b>Feedback Individual Mode Cool</b>	<b>1:Cool</b>	<b>1 bit</b>	<b>CRT</b>
-----------	--------------------------------------	---------------	--------------	------------

This object is used to monitor the air condition unit status individually. If value 1 is received from this object, the operating mode is cool.

DPT: 1.002 (Boolean)

<b>16</b>	<b>Individual Mode Fan</b>	<b>1:Set Mode Fan/0:Nothing</b>	<b>1 bit</b>	<b>CWT</b>
-----------	----------------------------	---------------------------------	--------------	------------

This object is used to change the air conditioner's operating mode to fan mode via a 1-bit object individually. If the value 1 is sent over the 1-bit value, the air conditioning unit will switch to fan mode.

DPT: 1.002 (Boolean)

<b>17</b>	<b>Feedback Individual Mode Fan</b>	<b>1:Fan</b>	<b>1 bit</b>	<b>CRT</b>
-----------	-------------------------------------	--------------	--------------	------------

This object is used to monitor the air condition unit status individually. If value 1 is received from this object, the operating mode is the fan.

DPT: 1.002 (Boolean)

<b>18</b>	<b>Individual Mode Dry</b>	<b>1:Set Mode Dry/0:Nothing</b>	<b>1 bit</b>	<b>CW</b>
-----------	----------------------------	---------------------------------	--------------	-----------

This object is used to change the air conditioner's operating mode to dry mode via a 1-bit object individually. If the value 1 is sent over the 1-bit value, the air conditioning unit will switch to dry mode.

DPT: 1.002 (Boolean)

<b>19</b>	<b>Feedback Individual Mode Dry</b>	<b>1:Dry</b>	<b>1 bit</b>	<b>CRT</b>
-----------	-------------------------------------	--------------	--------------	------------

This object is used to monitor the air condition unit status individually. If value 1 is received from this object, the operating mode is dry.

DPT: 1.002 (Boolean)

<b>20</b>	<b>Operating Mode +/-</b>	<b>1:Increase/0:Decrease</b>	<b>1 bit</b>	<b>CW</b>
-----------	---------------------------	------------------------------	--------------	-----------

This object changes between operating modes as +/- via 1-bit value. This object is used to switch between the operating modes of the air conditioning unit in a loop. If a continuous value is sent in the increasing direction, it follows the following sequence and returns to the beginning when reaches the last mode.

1:Increase: auto->heat->cool->fan->dry  
0:Decrease: dry -> fan -> cool -> heat->auto

DPT: 1.008 (up/down)

<b>20</b>	<b>Operating Mode +/-</b>	<b>0:Up/1:Down</b>	<b>1 bit</b>	<b>CWT</b>
-----------	---------------------------	--------------------	--------------	------------

This object changes between operating modes as +/- via 1-bit value. This object is used to switch between the operating modes of the air conditioning unit in a loop. If a continuous value is sent in the increasing direction, it follows the following sequence and returns to the beginning when reaches the last mode.

0:Up: auto->heat->cool->fan->dry  
1:Down: dry -> fan -> cool -> heat->auto

DPT: 1.008 (Up/Down)

<b>21</b>	<b>Operating Mode Text Feedback</b>	<b>Text Feedback</b>	<b>14 bytes</b>	<b>CRT</b>
-----------	-------------------------------------	----------------------	-----------------	------------

This object is used to monitor the operation mode of the air conditioning unit in text format via the KNX bus line. Naming can be made for each operating mode with a length of 14 bytes.

DPT: 16.001 (Character String (ISO 8859-1))

<b>57</b>	<b>Energy Saver Mode</b>	<b>1:Start/0:Stop</b>	<b>1 bit</b>	<b>CWT</b>
-----------	--------------------------	-----------------------	--------------	------------

This object is used to initiate energy saver mode. If a value of 1 is sent over this object, energy mode starts, and a value of 0 stops.

DPT: 1.010 (start/stop)

<b>57</b>	<b>Energy Saver Mode</b>	<b>0:Start/1:Stop</b>	<b>1 bit</b>	<b>CWT</b>
-----------	--------------------------	-----------------------	--------------	------------

This object is used to initiate energy saver mode. If a value of 0 is sent over this object, energy mode starts, and a value of 1 stops.

DPT: 1.010 (start/stop)

<b>58</b>	<b>Feedback Energy Saver Mode</b>	<b>1:Start/0:Stop</b>	<b>1 bit</b>	<b>CWT</b>
-----------	-----------------------------------	-----------------------	--------------	------------

This object is used to determine if the air conditioner unit is in energy saver mode.

DPT: 1.010 (start/stop)

<b>58</b>	<b>Feedback Energy Saver Mode</b>	<b>0:Start/1:Stop</b>	<b>1 bit</b>	<b>CWT</b>
-----------	-----------------------------------	-----------------------	--------------	------------

This object is used to determine if the air conditioner unit is in energy saver mode.

DPT: 1.010 (start/stop)

<b>59</b>	<b>Energy Saver Mode Timer Duration</b>	<b>0-255 min</b>	<b>1 byte</b>	<b>CWT</b>
-----------	---	------------------	---------------	------------

This object is used to determine how long the air conditioner unit stays in energy saver mode. Up to 255 minutes can be set with a 1-byte value.

DPT: 20.013 (time delay)

<b>60</b>	<b>Energy Saver Mode Setpoint Shifting</b>	<b>Temperature (Celsius)</b>	<b>2 bytes</b>	<b>CWT</b>
-----------	--	------------------------------	----------------	------------

This object is used to determine the shifting value for making a setpoint temperature setting. The values between 1-4 can be selected for shifting.

DPT: 9.001 (temperature (°C))

<b>61</b>	<b>Energy Save Mode Fan Speed</b>	<b>1:Fan1 / 2:Fan2 / 3:Fan3 / 4:Fan4 / 5:Fan5</b>	<b>1 byte</b>	<b>CWT</b>
-----------	-----------------------------------	---	---------------	------------

This object is used to determine the fan speed for energy saver mode. A value of 1 for fan speed 1, 2 for fan speed 2, 3 for fan speed 3, 4 for fan speed 4 and 5 for fan speed 5 must be sent.

DPT: 5.100 (fan stage (0..255))

<b>62</b>	<b>Power Saver Mode</b>	<b>1:Start/0:Stop</b>	<b>1 bit</b>	<b>CWT</b>
-----------	-------------------------	-----------------------	--------------	------------

This object is used to initiate power saver mode. If a value of 1 is sent over this object, power mode starts, and a value of 0 stops.

DPT: 1.010 (start/stop)

<b>62</b>	<b>Power Saver Mode</b>	<b>0:Start/1:Stop</b>	<b>1 bit</b>	<b>CWT</b>
-----------	-------------------------	-----------------------	--------------	------------

This object is used to initiate power saver mode. If a value of 0 is sent over this object, power mode starts, and a value of 1 stops.

DPT: 1.010 (start/stop)

<b>63</b>	<b>Feedback Power Saver Mode</b>	<b>1:Start/0:Stop 0:Start/1:Stop</b>	<b>1 bit</b>	<b>CRT</b>
-----------	----------------------------------	--	--------------	------------

This object is used to determine if the air conditioner unit is in power saver mode.

DPT: 1.010 (start/stop)

<b>64</b>	<b>Power Saver Time Duration</b>	<b>0-255 min</b>	<b>1 byte</b>	<b>CWT</b>
-----------	----------------------------------	------------------	---------------	------------

This object is used to determine how long the air conditioner unit stays in power saver mode. Up to 255 minutes can be set with a 1-byte value.

DPT: 20.013 (time delay)

<b>65</b>	<b>Power Saver Mode Setpoint Shifting</b>	<b>Temperature (Celsius)</b>	<b>2 bytes</b>	<b>CWT</b>
-----------	---	------------------------------	----------------	------------

This object is used to determine the shifting value for making setpoint temperature settings of power saver mode. The values between 1-4 can be selected for shifting.

DPT: 9.001 (temperature (°C))

<b>66</b>	<b>Power Saver Mode Fan Speed</b>	<b>1:Fan1 / 2:Fan2 / 3:Fan3 / 4:Fan4 / 5:Fan5</b>	<b>1 byte</b>	<b>CWT</b>
-----------	-----------------------------------	---	---------------	------------

This object is used to determine the fan speed for power saver mode. A value of 1 for fan speed 1, 2 for fan speed 2, 3 for fan speed 3, 4 for fan speed 4 and 5 for fan speed 5 must be sent.

DPT: 5.100 (fan stage (0..255))

<b>67</b>	<b>Winter Mode</b>	<b>1:Start/0:Stop</b>	<b>1 bit</b>	<b>CWT</b>
-----------	--------------------	-----------------------	--------------	------------

This object is used to initiate winter mode. If a value of 1 is sent over this object, winter mode starts, and a value of 0 stops.

DPT: 1.010 (start/stop)

<b>67</b>	<b>Winter Mode</b>	<b>0:Start/1:Stop</b>	<b>1 bit</b>	<b>CWT</b>
-----------	--------------------	-----------------------	--------------	------------

This object is used to initiate winter mode. If a value of 0 is sent over this object, winter mode starts, and a value of 1 stops.

DPT: 1.010 (start/stop)

<b>68</b>	<b>Feedback Winter Mode</b>	<b>1:Start/0:Stop 0:Start/1:Stop</b>	<b>1 bit</b>	<b>CRT</b>
-----------	-----------------------------	--	--------------	------------

This object is used to determine if the air conditioner unit is in winter mode.

DPT: 1.010 (start/stop)

<b>69</b>	<b>Winter Mode Time Duration</b>	<b>0-255 min</b>	<b>1 byte</b>	<b>CWT</b>
-----------	----------------------------------	------------------	---------------	------------

This object is used to determine how long the air conditioner unit stays in winter mode. Up to 255 minutes can be set with a 1-byte value.

DPT: 20.013 (time delay)

<b>70</b>	<b>Winter Mode Setpoint</b>	<b>Temperature (Celsius)</b>	<b>2 bytes</b>	<b>CWT</b>
-----------	-----------------------------	------------------------------	----------------	------------

This object is used to determine the shifting value for making setpoint temperature settings of winter mode. The values between 1-4 can be selected for shifting.

DPT: 9.001 (temperature (°C))

<b>71</b>	<b>Winter Mode Fan Speed</b>	<b>1:Fan1 / 2:Fan2 / 3:Fan3 / 4:Fan4 / 5:Fan5</b>	<b>1 byte</b>	<b>CWT</b>
-----------	------------------------------	---	---------------	------------

This object is used to determine the fan speed for winter mode. A value of 1 for fan speed 1, 2 for fan speed 2, 3 for fan speed 3, 4 for fan speed 4 and 5 for fan speed 5 must be sent.

DPT: 5.100 (fan stage (0..255))

<b>72</b>	<b>Summer Mode</b>	<b>1:Start/0:Stop</b>	<b>1 bit</b>	<b>CWT</b>
-----------	--------------------	-----------------------	--------------	------------

This object is used to initiate summer mode. If a value of 1 is sent over this object, summer mode starts, and a value of 0 stops.

DPT: 1.010 (start/stop)

<b>72</b>	<b>Summer Mode</b>	<b>0:Start/1:Stop</b>	<b>1 bit</b>	<b>CWT</b>
-----------	--------------------	-----------------------	--------------	------------

This object is used to initiate summer mode. If a value of 0 is sent over this object, summer mode starts, and a value of 1 stops.

DPT: 1.010 (start/stop)

<b>73</b>	<b>Feedback Summer Mode</b>	<b>1:Start/0:Stop</b>	<b>1 bit</b>	<b>CRT</b>
-----------	-----------------------------	-----------------------	--------------	------------

This object is used to determine if the air conditioner unit is in summer mode.

DPT: 1.010 (start/stop)

<b>74</b>	<b>Summer Mode Time Duration</b>	<b>0-255 min</b>	<b>1 byte</b>	<b>CWT</b>
-----------	----------------------------------	------------------	---------------	------------

This object is used to determine how long the air conditioner unit stays in summer mode. Up to 255 minutes can be set with a 1-byte value.

DPT: 20.013 (time delay)

<b>75</b>	<b>Summer Mode Setpoint</b>	<b>Temperature (Celsius)</b>	<b>2 bytes</b>	<b>CWT</b>
-----------	-----------------------------	------------------------------	----------------	------------

This object is used to determine the shifting value for making setpoint temperature settings of summer mode. The values between 1-4 can be selected for shifting.

DPT: 9.001 (temperature (°C))

<b>76</b>	<b>Summer Mode Fan Speed</b>	<b>1:Fan1 / 2:Fan2 / 3:Fan3 / 4:Fan4 / 5:Fan5</b>	<b>1 byte</b>	<b>CWT</b>
-----------	------------------------------	---	---------------	------------

This object is used to determine the fan speed for summer mode. A value of 1 for fan speed 1, 2 for fan speed 2, 3 for fan speed 3, 4 for fan speed 4 and 5 for fan speed 5 must be sent.

DPT: 5.100 (fan stage (0..255))

## 4.5. Fan Group Objects

In this section, fan group objects and their properties are described.

Object number	Object Name	Function	Type	Flags
22	Fan Speed Percent	Threshold defined in parameter	1 byte	CWT

This object is used to set fan speeds in percentages. 5 different fan speeds can be configured according to the specified threshold values. For example, select Fan speed 1 lower limit is 30% and Fan speed 2 lower limit is 55%. If a 45% value is sent over this object, fan speed will be fan1.

DPT: 5.001 (Percentage(0...100%))

22	Fan Speed Enumerated	0:Auto/1:Speed1/...4:Speed4	1 byte	CWT
----	----------------------	-----------------------------	--------	-----

This object is used to determine the fan speed by selecting between 0-4 values. For example, if value 1 is sent, fan speed will be fan 1.

DPT: 5.001 (Fan Stage (0..255))

23	Feedback Fan Speed	0:Auto/1:Speed1/...4:Speed4	1 byte	CRT
----	--------------------	-----------------------------	--------	-----

This object is used to receive current fan speed in between 0-4 values.

DPT: 5.001 (Fan Stage (0..255))

24	Fan Speed Auto/Manual	1:Auto/0:Manual	1 bit	CWT
----	-----------------------	-----------------	-------	-----

This object is used to select fan speed Auto individually. If a value 1 is sent, the fan speed will be fan Auto. After this object is disabled, means value 0 is sent, fan speed returns the state before auto fan speed set.

DPT: 1.001 (Switch)

25	Feedback Fan Speed Auto /Manual	1:Auto/0:Manual	1 bit	CRT
----	---------------------------------	-----------------	-------	-----

This object is used to monitor the fan speed Auto of the air conditioner.

DPT: 1.001 (Switch)

26	Individual Fan Speed 1	1:Set Fan Speed1/0:Nothing	1 bit	CWT
----	------------------------	----------------------------	-------	-----

This object is used to select fan speed 1 individually. If a value 1 is sent, the fan speed will be fan 1.

DPT: 1.002 (Boolean)

<b>27</b>	<b>Feedback Individual Fan Speed 1</b>	<b>1:Fan Speed 1</b>	<b>1 bit</b>	<b>CRT</b>
-----------	--	----------------------	--------------	------------

This object is used to monitor the fan speed 1 of the air conditioner.

DPT: 1.002 (Boolean)

<b>28</b>	<b>Individual Fan Speed 2</b>	<b>1:Set Fan Speed 2/0:Nothing</b>	<b>1 bit</b>	<b>CWT</b>
-----------	-------------------------------	------------------------------------	--------------	------------

This object is used to select fan speed 2 individually. If a value 1 is sent, the fan speed will be fan 2.

DPT: 1.002 (Boolean)

<b>29</b>	<b>Feedback Individual Fan Speed 2</b>	<b>1:Fan Speed 2</b>	<b>1 bit</b>	<b>CRT</b>
-----------	--	----------------------	--------------	------------

This object is used to monitor the fan speed 2 of the air conditioner.

DPT: 1.002 (Boolean)

<b>30</b>	<b>Individual Fan Speed 3</b>	<b>1:Set Fan Speed 3/0:Nothing</b>	<b>1 bit</b>	<b>CW</b>
-----------	-------------------------------	------------------------------------	--------------	-----------

This object is used to select fan speed 3 individually. If a value 1 is sent, the fan speed will be fan 3.

DPT: 1.002 (Boolean)

<b>31</b>	<b>Feedback Individual Fan Speed 3</b>	<b>1:Fan Speed 3</b>	<b>1 bit</b>	<b>CRT</b>
-----------	--	----------------------	--------------	------------

This object is used to monitor the fan speed 3 of the air conditioner.

DPT: 1.002 (Boolean)

<b>32</b>	<b>Individual Fan Speed 4</b>	<b>1:Set Fan Speed 4/0:Nothing</b>	<b>1 bit</b>	<b>CWT</b>
-----------	-------------------------------	------------------------------------	--------------	------------

This object is used to select fan speed 4 individually. If a value 1 is sent, the fan speed will be fan 4.

DPT: 1.002 (Boolean)

<b>33</b>	<b>Feedback Individual Fan Speed 4</b>	<b>1:Fan Speed 4</b>	<b>1 bit</b>	<b>CRT</b>
-----------	--	----------------------	--------------	------------

This object is used to monitor the fan speed 4 of the air conditioner.

DPT: 1.002 (Boolean)

<b>34</b>	<b>Fan Speed +/-</b>	<b>1:Increase/0:Decrease</b>	<b>1 bit</b>	<b>CWT</b>
-----------	----------------------	------------------------------	--------------	------------

This object is used to change between fan speed levels with a 1-bit value. If a continuous value is sent in the increasing direction, it follows the following sequence. Additionally, if the “Loop the sequence” parameter is activated, increasing or decreasing that returns the mode to the beginning when it reaches the last mode.

- 1:Increase : auto->fan speed 1->fan speed 2->fan speed 3-> fan speed 4
- 0:Decrease : fan speed 4->fan speed 3->fan speed 2->fan speed 1->auto

DPT: 1.008 (Up / Down)

<b>34</b>	<b>Fan Speed +/-</b>	<b>0:Up/1:Down</b>	<b>1 bit</b>	<b>CWT</b>
-----------	----------------------	--------------------	--------------	------------

This object is used to change between fan speed levels with a 1-bit value. If a continuous value is sent in the increasing direction, it follows the following sequence. Additionally, if the “Loop the sequence” parameter is activated, increasing or decreasing that returns the mode to the beginning when it reaches the last mode.

- 0:Up: auto->fan speed 1->fan speed 2->fan speed 3-> fan speed 4
- 1:Down: fan speed 4->fan speed 3->fan speed 2->fan speed 1 ->auto

DPT: 1.008 (Up / Down)

<b>35</b>	<b>Fan Speed Text Feedback</b>	<b>Fan Speed Text</b>	<b>14 bytes</b>	<b>CRT</b>
-----------	--------------------------------	-----------------------	-----------------	------------

This object is used to receive the air conditioner unit's fan speed status via text format. For each fan speed status up to 14 bytes are allowed to determine the name of the fan speeds.

DPT: 16.001 (Character String (ISO8859-1))

## 4.6. Vertical Swing Group Objects

In this section, vane group objects and their properties are described.

Object Number	Object Name	Function	Type	Flags
36	Swing Position Control	0 = Swing On, 1 = Pos1, 2 = Pos 2, 3 = Pos 3, 4 = Pos 4	1 byte	CW

This object is used to receive the current air deflector position in between 0-4 values.

37	Swing Position Feedback	0 = Swing On, 1 = Pos1, 2 = Pos 2, 3 = Pos 3, 4 = Pos 4	1 byte	CRT
----	-------------------------	---	--------	-----

This object is used to receive the air conditioner unit's air deflector position status via 1 byte object.

38	Vertical Swing +/-	1:Increase / 0:Decrease	1 bit	CWT
----	--------------------	-------------------------	-------	-----

This object is used to change between air deflector position levels with a 1-bit value. If a continuous value is sent in the increasing direction, it follows the following sequence. Additionally, if the "Loop the sequence" parameter is activated, increasing or decreasing that returns the mode to the beginning when it reaches the last mode.

1:Increase : Swing ->pos 1->pos 2->pos 3->pos 4

0:Decrease : pos 4->pos 3->pos 2->pos 1->Swing

DPT: 1.008 (Up/down)

38	Vertical Swing +/-	0:Up/1:Down	1 bit	CWT
----	--------------------	-------------	-------	-----

This object is used to change between air deflector position levels with a 1-bit value. If a continuous value is sent in the increasing direction, it follows the following sequence. Additionally, if the "Loop the sequence" parameter is activated, increasing or decreasing that returns the mode to the beginning when it reaches the last mode.

0:Up : Swing->pos 1->pos 2->pos 3->pos 4

1:Down : pos 4->pos 3->pos 2->pos 1->Swing

DPT: 1.008 (Up/Down)

39	Feedback Vertical Swing Text	Vertical Swing Text	14 bytes	CRT
----	------------------------------	---------------------	----------	-----

---

This object is used to receive the air conditioner unit's vertical swing position status via text format. For each vertical swing position status (pos1, pos2, pos3, pos4, SWING) up to 14 bytes are allowed to determine the name of the vertical swing positions.

DPT: 16.001 (Character String (ISO8859-1))

---

## 4.7. Temperature Group Objects

In this section, temperature group objects and their properties are described.

Object Number	Object Name	Function	Type	Flags
40	Setpoint Temperature	Temperature(Celsius)	2 bytes	CWT

This object is used to modify the setpoint temperature to be sent to the AC indoor unit according to the desired value.

DPT: 9.001 (Temperature °C)

41	Feedback Setpoint Temperature	Temperature(Celsius)	2 bytes	CRT
----	-------------------------------	----------------------	---------	-----

This object is used to monitor the air conditioner unit setpoint temperature from the KNX bus line.

DPT: 9.001 (Temperature °C)

42	Setpoint Temperature +/-	1:Increase/0:Decrease	1 bit	CWT
----	--------------------------	-----------------------	-------	-----

This object is used to change the setpoint temperature by increasing or decreasing by a 1-bit value. If a continuous value is sent in the increasing direction, it is increased up to the highest temperature value. Likewise, if a continuous value is sent in the decreasing direction, it is decreased up to the lowest temperature value.

DPT: 1.008 (Up/down)

42	Setpoint Temperature +/-	0:Up/1:Down	1 bit	CWT
----	--------------------------	-------------	-------	-----

This object is used to change the setpoint temperature by increasing or decreasing by a 1-bit value. If a continuous value is sent in the increasing direction, it is increased up to the highest temperature value. Likewise, if a continuous value is sent in the decreasing direction, it is decreased up to the lowest temperature value.

DPT: 1.008 (Up/Down)

43	KNX Ambient Temperature	Temperature (Celsius)	2 bytes	CRWT
----	-------------------------	-----------------------	---------	------

This object is used to receive the KNX ambient temperature from the KNX bus line. This option only works when the Gateway operates in master mode.

DPT: 9.001 (Temperature °C)

<b>44</b>	<b>Analog Thermistor Temperature Feedback</b>	<b>Temperature (Celsius)</b>	<b>2 bytes</b>	<b>CRT</b>
-----------	---	------------------------------	----------------	------------

While the temperature data read with the help of the temperature sensor attached to the gateway is sent directly to the air conditioner, the temperature value read from the sensor can be sent to the line through this communication interface.

DPT: 9.001 (Temperature °C)

<b>45</b>	<b>Feedback Ambient Temperature</b>	<b>Temperature (Celsius)</b>	<b>2 bytes</b>	<b>CRT</b>
-----------	---	------------------------------	----------------	------------

This object is used to read the ambient temperature that sent to air conditioner or readed from the air conditioner.

- When “Enable ambient temperature” parameter is selected “No” and “Ambient temperature feedback send state” is different from “Disable”, this object shows the ambient temperature readed from air conditioner indoor temperature sensor.
- When “Enable ambient temperature” parameter is selected “Yes”, this object shows the ambient temperature sended to air conditioner. If there is no ambient temperature coming from KNX bus through 5 mins, the device select ambient temperature reference as “AC indoor sensor temp” until ambient temperature value sends over KNX again. Temperature value readed from indoor unit can be observed in KNX bus.

DPT: 9.001 (Temperature °C)

## 4.8. Scene Group Objects

In this section, scene group objects and their properties are described.

Object Number	Object Name	Function	Type	Flags
77	Scene	1-64:Run / 128+Scene:Storage	1 byte	CWT

This object is used to execute or store a scenario with a specified scenario number. According to the KNX scenario numbers could be between 1-64. If a scenario wanted to be stored, the scenario number + 128 value must be sent. Also, this object is always visible.

DPT: 18.001 (Scene Control)

78, 79, 80 81, 82	Scene 1...5 Run	1:Run Scene/0:Nothing	1 bit	CWT
----------------------	-----------------	-----------------------	-------	-----

This object is used to run the associated scenario number 1 to 5. These scenario numbers are listed on the scene parameter page.

DPT: 1.002 (Boolean)

83, 84, 85, 86, 87	Scene 1...5 Storage	1:Storage Scene/0:Nothing	1 bit	CWT
-----------------------	---------------------	---------------------------	-------	-----

This object is used to record the current status of the air conditioner unit to the desired scenario from 1 to 5. The desired scenario number (e.g., 68) can be assigned to these scenes.

DPT: 1.002 (Boolean)

88	Feedback Current Scene	1-64 Current Scene	1 byte	CRT
----	------------------------	--------------------	--------	-----

This object is used to view the current scene of the air conditioner unit. Scene values can be monitored from the KNX bus line. According to KNX standards scene values should be between 1-64.

DPT: 17.001 (Scene Number)

## 4.9. Special Group Objects

In this section, special functions group objects and their properties are described.

Object Number	Object Name	Function	Type	Flags
93	Feedback Working Hours Counter	Working Hours Counter	4 bytes	CRT

This object is used to detect the air conditioner's operating hours in working mode. When the air conditioner starts to work, the working hours counter starts to count the value.

DPT: 13.100 (Time Lag (s))

94	Feedback Working Hours Alert	1:Alarm/0:No Alarm	1 bit	CRT
----	------------------------------	--------------------	-------	-----

This object is used to view the air conditioner unit's alert status when the specified working hours operation period ends. Counter creates an alert to warn the user.

DPT: 1.005 (Alarm)

95	Reset Hours Counter	1:Reset/0:Nothing	1 bit	CWT
----	---------------------	-------------------	-------	-----

This object is used to reset the counted hours by the working hours counter function. If a value 1 is sent via this object, the working hours counter will be reset.

DPT: 1.015 (Reset)

46	Window Contact Status	0-Opened;1-Closed 0-Closed;1-Opened	1 bit	CRWT
----	-----------------------	--	-------	------

This object is used to receive the status of the window contact. It can be configured which value to which it means from the parameter page.

DPT: 1.019 (Window/Door)

47	Window Switch-Off Delay	0-255 min	1 byte	CWT
----	-------------------------	-----------	--------	-----

This object is used to switch off the air condition unit according to delay time by a 1-byte value.

DPT: 20.013 (Time Delay)

<b>48</b>	<b>Standby Function</b>	<b>1:Occupied/0:Not Occupied 1:Start/0:Stop</b>	<b>1 bit</b>	<b>CWT</b>
-----------	-------------------------	---	--------------	------------

This object is used to control the standby function of the air conditioner unit. The object also can be parameterized as start/stop or occupied/not occupied.

DPT: 1.010 (Start/Stop)

<b>49</b>	<b>Feedback Stanby Function</b>	<b>1:Occupied/0:Not Occupied 1:Start/0:Stop</b>	<b>1 bit</b>	<b>CRT</b>
-----------	---------------------------------	---	--------------	------------

This object is used to view the air condition unit's standby function status.

DPT: 1.010 (Start/Stop)

<b>50</b>	<b>Standby Function Delay</b>	<b>0-255 min</b>	<b>1 byte</b>	<b>CWT</b>
-----------	-------------------------------	------------------	---------------	------------

This object is used to set the delay time of the air conditioner unit's standby function.

DPT: 20.013 (Time Delay)

<b>51</b>	<b>Stanby Function Setpoint Shifting</b>	<b>Temperature (Celsius)</b>	<b>2 bytes</b>	<b>CWT</b>
-----------	--	------------------------------	----------------	------------

This object is used to set the setpoint shifting of the air conditioner unit's standby function.

DPT: 9.001 (Temperature (°C))

<b>52</b>	<b>Stanby Function Setpoint Shifting</b>	<b>0-255 min</b>	<b>1 byte</b>	<b>CWT</b>
-----------	--	------------------	---------------	------------

This object is used to set the delay time of the air conditioner unit's standby function.

DPT: 20.013 (Time Delay)

<b>53</b>	<b>Standby Function Secondary Setpoint Shifting</b>	<b>Temperature (Celsius)</b>	<b>2 bytes</b>	<b>CWT</b>
-----------	---	------------------------------	----------------	------------

This object is used to set the setpoint shifting of the air conditioner unit's standby function.

DPT: 9.001 (Temperature (°C))

<b>54</b>	<b>Timer Function</b>	<b>0-Stop;1:Start 0-Start;1:Stop</b>	<b>1 bit</b>	<b>CWT</b>
-----------	-----------------------	--	--------------	------------

This object is used to control the timer function of the air conditioner unit. The start and stop operations can be determined with which value will be used. Value 1 can be start function or stop according to settings. The air conditioner will stop after time is ended.

DPT: 1.010 (start/stop)

<b>55</b>	<b>Feedback Timer Function</b>	<b>0-Stop;1:Start 0-Start;1:Stop</b>	<b>1 bit</b>	<b>CRT</b>
-----------	--------------------------------	--	--------------	------------

This object is used to view the timer function status of the air conditioner unit.

DPT: 1.010 (start/stop)

<b>56</b>	<b>Timer Function</b>	<b>1-65535 min</b>	<b>1 byte</b>	<b>CWT</b>
-----------	-----------------------	--------------------	---------------	------------

This object is used to specify the time duration of the timer function.

DPT: 20.013 (Time Delay)

## Appendix

Error Code KNX	Error Definition
403	Comms fault between boards - check inverter error detail for which 2 boards, check transformer, bus voltage and inter-connecting cables
900	Lossnay unit in test run
1102	High compressor discharge temperature. Discharge temperature has exceeded 110 C or more. Short of refrigerant. Discharge thermistor.
1111	Low pressure/temperature fault - check thermistors (TH2, TH3, TH4), gas charge, indoor fan, heat exchanger and filter.
1112	Low pressure/temperature fault - check thermistors (TH2, TH3, TH4), gas charge, indoor fan, heat exchanger and filter.
1113	Low pressure/temperature fault - check thermistors (TH2, TH3, TH4), gas charge, indoor fan, heat exchanger and filter.
1202	Preliminary fault to 1102
1204	Preliminary heat exchanger gas temperature sensor fault - check thermistors 10a and 10b
1205	Preliminary thermistor fault (TH5)
1211	Preliminary thermistor fault (TH2)
1214	Preliminary thermistor fault (THHS)
1216	Preliminary thermistor fault (TH7)
1217	Preliminary thermistor fault (TH8)
1219	Preliminary thermistor fault (TH9)
1221	Preliminary thermistor fault (TH6)
1243	Preliminary thermistor fault (TH10)
1301	Low pressure fault (63L operation) low pressure sensor sensing less than 1 bar immediately before starting
1302	High pressure fault - check pressure in system for more than 29 bar (R407c) 38 bar (R410A). Check high pressure sensor against gauge pressure
1368	Pressure sensor fault (PS1) at BC - compare pressure reading on SW1 on O/C
1370	Pressure sensor fault (PS3) at BC - compare pressure reading on SW1 on O/C
1402	Preliminary fault to 1302
1500	System overcharge. Abnormal low compressor superheat - discharge thermistor TH4
1501	High compressor shell temp - check for shortage of gas, insufficient indoor index running (comms room units)
1505	Suction pressure abnormal - generated by low pressure sensor detecting a vacuum - check for blockage, closed valve or sensor fault

2500	Detecting lack of water flow on a water circuit
2502	I/C has water level in drip tray, when the unit was running in cooling (temperature sensors - check for open or closed circuit and operation of pump)
2503	I/C has water level in drip tray, when the unit was running in cooling (float sensors - check for closed circuit on float switch and operation of pump)
2600	Water leak from humidifier
4100	Compressor over current protection on Mr Slim with M-net interface - check inverter or compressor
4101	Compressor over current protection on Mr Slim with M-net interface - check inverter or compressor
4102	Open phase fault - check power supply and noise filter for loss of phase, check wiring and fuses
4103	Reverse phase fault - check phase rotation, loss of phase through the noise filter, fuse blown and high pressure switch open at power on
4106	Transmission power supply fault - check wiring, high current, incorrect voltage on transmission line and/or M-Net board
4108	Over current protection on DOL compressor - check power supply, contactor and compressor
4115	Power supply abnormal - check power, fuses, connections and PCB
4116	Fan motor abnormal - check fan motor and board (relates to indoor unit or Lossnay unit)
4124	Thermal switch (49C) open circuit on Mr Slim on M-Net - reset and check pressures and air flow
4210	Compressor over current problem - check inverter balance. Compressor and inverter
4220	Low inverter board BUS voltage. Less than 289 VdcDC is detected. - check mains supply
4225	Low DC voltage on Vdc on fan inverter - check CNVdc for 300Vdc on diode stack and check mains power supply to outdoor unit
4230	High temperature on heat sink on inverter - check for blockages in air duct failure of INV fan or failure of thermistor
4235	Fan inverter heat sink overheat protection. Reduced airflow through heat sink. Fan motor problem. THHS thermistor problem
4240	Over current protection. If high current is detected for more than 10 minutes - check inverter balance. Reduced airflow through heat sink
4245	Over current protection. Possible ACCT current sensor fault. Should read 280 ohms between pins 1&2 and across pins 3&4
4250	Over current protection. Inverter IPM problem. Compressor lock - check inverter balance
4255	Inverter cooling fan problem - if high static fan is used then check that SW3-9 is on
4260	Preliminary inverter heat sink overheat protection. Reduced airflow through heat sink. Fan motor problem. THHS thermistor problem
5101	Thermistor fault at indoor/outdoor unit - check fault code address
5102	Thermistor fault at indoor/outdoor unit - check fault code address
5103	Thermistor fault at indoor/outdoor unit - check fault code address

<b>5104</b>	Thermistor fault at indoor/outdoor unit - check fault code address (indoor fault - check SW7-3 is off)
<b>5105</b>	TH5 open/short circuit - check if the TH is disconnected from the board
<b>5106</b>	TH6 open/short circuit - check if the TH is disconnected from the board
<b>5107</b>	TH7 open/short circuit - check if the TH is disconnected from the board
<b>5108</b>	TH8 open/short circuit - check if the TH is disconnected from the board
<b>5109</b>	TH9 open/short circuit - check if the TH is disconnected from the board
<b>5110</b>	TH10 open/short circuit - check if the TH is disconnected from the board
<b>5111</b>	BC box thermistor error - TH11 open/short circuit, disconnected from board/pipe
<b>5112</b>	BC box thermistor error - TH10 open/short circuit, disconnected from board/pipe
<b>5113</b>	BC box thermistor error - TH open/short circuit, disconnected from board/pipe
<b>5114</b>	BC box thermistor error - TH open/short circuit, disconnected from board/pipe
<b>5115</b>	BC box thermistor error - TH15 open/short circuit, disconnected from board/pipe
<b>5116</b>	BC box thermistor error - TH16 open/short circuit, disconnected from board/pipe
<b>5201</b>	Pressure sensor fault outdoor unit/BC box - check fault code address/SW1 pressure sensor readings
<b>5202</b>	Pressure sensor fault (PS2) in the BC box
<b>5203</b>	Pressure sensor fault (PS3) in the BC box
<b>5300</b>	A-Control UH fault - see Mr Slim fault code list
<b>5301</b>	Current sensor fault, ACCT or DCCT - check inv. error details
<b>5401</b>	Temperature sensor fault - check CN30 for humidity sensor
<b>5701</b>	Loose float switch connector - check switch, check CN4F on indoor unit
<b>6201</b>	TB7 transmission line communication error - check for voltage abnormality/short
<b>6202</b>	Transmission processor hardware error - check for noise/short on M-Net cable
<b>6600</b>	Repeat address fault - two or more units are assigned the same address - correct the repeated address
<b>6601</b>	Polarity setting error - no voltage or short circuit on the m-net transmission line
<b>6602</b>	Hardware error of transmission processor. Noise interference. Polarity problem on TB7
<b>6603</b>	Bus circuit busy - check if indoor unit, Lossnay unit or anything else has been wired into TB7, instead of TB3
<b>6607</b>	Communication issue - no response back from unit whilst system is operational
<b>6608</b>	Communication error - loss of voltage or noise entering the transmission line
<b>6700</b>	K control communication error - R22 type unit connected onto M-Net circuit comms error

6701	K control communication error - R22 type unit connected onto M-Net circuit comms error
6702	K control duplicate address error - two or more R22 type units connected onto M-Net circuit with the same address
6750	K control communication error - R22 type unit connected onto M-Net circuit comms error
6751	R22 R/A thermistor fault (P1)
6752	R22 frost protection at I/C (P6)
6753	Comms fault between O/C and I/C
6754	R22 drain fault (P5)
6755	R22 drain fault (P5)
6756	R22 frost protection at I/C (P6)
6757	System error
6758	Comms fault between I/C and O/C
6761	R22 R/A thermistor fault (P1)
6762	R22 TH2 fault check resistance (P2)
6763	R22 Comms fault between I/C and O/C
6764	R22 drain fault (P4)
6765	R22 drain fault (P5)
6766	R22 frost protection at I/C (P6)
6767	R22 comms fault between I/C and O/C
6771	K abnormality - high pressure abnormality or low pressure abnormality
6772	K abnormality - inner thermostat function, discharge temperature abnormality, shell thermostat function, over current protection
6773	K abnormality - radiator plate thermostat function
6774	K abnormality - outdoor thermistor abnormality
6775	K abnormality - pressure sensor abnormality, indoor/outdoor communication error
6776	K abnormality - over current shut-off
6777	K abnormality - system error
6778	K abnormality - normal
6779	K abnormality - refrigerant overcharge, abnormal voltage, abnormal CT sensor
6830	Comms fault between I/C and R/C check connections to MA R/C check for 12 Vdc check R/C not set sub controller
6831	MA R/C communication fault - check connections on TB15 or that the controller was removed while the I/C was powered

6832	MA controller comms fault - check cable length no bigger than 500m, check connection and type of cable used, check R/C not set sub on field settings
6833	MA controller comms fault - check cable length no bigger than 500m, check connection and type of cable used, check R/C not set sub on field settings
6834	MA controller comms fault - check cable length no bigger than 500m, check connection and type of cable used, check R/C not set sub on field settings
6840	A-Control E6/E8 fault - see Mr Slim fault code list
6841	A-Control E7/E9 fault - see Mr Slim fault code list
6844	A-Control EA fault - see Mr Slim fault code list
6845	A-Control Eb fault - see Mr Slim fault code list
6846	A-Control EC fault - see Mr Slim fault code list
7100	Over capacity - (R2 150% index exceeded) (Y 130% index exceeded)
7101	Capacity setting error - SW2 set wrong on indoors, SW5 on YHMA outdoor, (SW3-10 on older kit)
7102	Error in number of connected units - loss of M-Net voltage (short or break), no power to BC, wrong SW5 setting on box, wrong box type
7105	Address setting error - OC or BC addressed wrong
7106	Attribute setting error - SW3-1 setting on a GUF
7107	Port setting error - check if too much capacity on a single port, wiring SW2 setting, wrong SW14 setting or wrong units on a box when using multiple boxes
7110	Check SW5-7 is correctly set
7111	Remote control sensor fault - SW1-1 on and no controllers fitted or faulty remote controller
7113	Function setting error - wrong SW5 setting or wrong resistors fitted on YHM-A
7117	Model setting error - SW5 set wrong or resistors in
7130	Incompatible equipment on M-Net - check split with MAC 399 wired onto the the TB5 line TB5 line, not the TB7

## Special Notes



If you encounter an error code not listed in this table, please contact your nearest Mitsubishi Electric technical service.

---

**CONTACT INFORMATION**

---

**THE INTERRA WEBSITE**

Interra provides documentation support via our website [www.interratechnology.com](http://www.interratechnology.com). This website is used as a means to make files and information easily available to customers. Accessible by using your favourite Internet browser, the website contains the following information:

- Information about our products and projects.
- Overview of Interra company and values.
- Product Support: Datasheets, product manuals, application descriptions, latest software releases, ETS databases and archived software.

**EUROPE, Türkiye**

Interra Technology Otomasyon A.S.  
Cumhuriyet mh. Kartal cd. Interra R&D Center  
No:95 34876 Kartal/Istanbul - Türkiye  
Tel: +90 (216) 326 26 40 Fax: +90 (216) 324 25 03  
Web adress: <http://www.interratechnology.com>