

INTERRA

CERTIFIED R&D CENTER OF AUTOMATION

Developer of Uniqueness

8/12 Channels Ethernet I/O Module

Product Manual



Information contained in this publication regarding device applications and the like is provided only for your convenience and may be superseded versions by updates. It is your responsibility to ensure that your application meets with your specifications.

INTERRA MAKES NO REPRESENTATIONS OR WARRANTIES OF ANY KIND WHETHER EXPRESS OR IMPLIED, WRITTEN OR ORAL, STATUTORY OR NONSTATUTORY, RELATED TO THE INFORMATION INCLUDING BUT NOT LIMITED TO ITS CONDITION, QUALITY, PERFORMANCE, MERCHANTABILITY OR FITNESS FOR PURPOSE.

Interra disclaims all liability arising from this information and its use. Use of Interra devices in life support and / or safety applications is entirely at the buyer's risk, and the buyer agrees to defend, indemnify and hold harmless Interra from any and all damages, claims, suits, or expenses resulting from such use. No licenses are conveyed, implicitly or otherwise under any Interra intellectual rights.

Trademarks

The Interra name and logo and the Interra ITR208-0005 & ITR212-0005 8/12 CHANNELS ETHERNET I/O MODULE are registered trademarks of Interra Technology in Turkey and other countries.

All other trademarks mentioned herein are property of the Interra Technology.

© 2021, Interra, Printed in Turkey, All Rights Reserved.



Printed on recycled paper.

TS EN ISO 9001:2008

TO OUR CUSTOMERS

One of our most important aims is to provide you with the best documentation possible to use successfully your Interra products. Focusing on this, we will keep on improving our documentation to better suit your needs. Our publications will be updated as new volumes as soon as changes are introduced.

If you have any questions or comments regarding this publication, do not hesitate to contact us:

E-mail: info@interra.com.tr

Tel: +90 (216) 326 26 40 Fax: +90 (216) 324 25 03

Most Current Product Manual

To obtain the most up-to-date version of this product manual, please visit our Web site at:

<http://www.interra.com.tr>

You can determine the version of an Interra document examining its literature number found on the bottom right corner of any page.

The first two letters of the literature are the type of document. The numbers that follow are the creation date of the document and the last letter is the version (e.g., PM181017001A is the version A of a product manual created on the date 17/10/18.)

CONTENTS

TECHNICAL INFORMATION	6
1. PRODUCT DESCRIPTION	7
1.1. PRODUCT FUNCTIONS	8
1.2. PRODUCT DIMENSIONS	9
1.3. CONNECTION DIAGRAM AND PROGRAMMING	9
4.1. HOME	13
4.2. OUTPUT CONFIGURATION	14
4.2.1. Global Visualization	14
4.2.2. Naming	15
4.2.3. Outputs	15
4.3. MANUAL	16
4.4. SETTINGS	17
4.4.1. Network Settings	17
4.4.2. Firmware Update	18
5.1. ON/OFF FUNCTION	18
5.1.1. Function Description	18
5.1.2. Parameters List	19
5.1.3. Configuration Description	21
5.1.3.1. Delays Configuration	21
5.1.3.2. Authorization description	22
5.2. TOGGLE FUNCTION	23
5.2.1. Function Description	23
5.2.2. Parameters List	23
5.2.3. Configuration Description	25
5.2.3.1. Edge Type	25
5.2.3.2. Action After Power Failure	26
5.2.3.3. Delays Configuration	26
5.2.3.4. Authorization Description	27
5.3. TIMER FUNCTION	27
5.3.1. Function Description	27
5.3.2. Parameters List	27
5.3.3. Configuration Description	30
5.3.3.1. Timer Operation	30
5.3.3.2. Pre Warning	30

5.3.3.3. Timer Retriggerability	30
5.3.3.4. Authorization description.....	31
5.4. SHUTTER FUNCTION	31
5.4.1. Function Description	31
5.4.2. Parameters List	32
5.4.3. Configuration Description	34
5.4.3.1. Configuration with 1 button.....	34
5.4.3.2. Configuration with 2 buttons.....	34
5.4.3.3. Motion Duration.....	35
5.4.3.4. Enabling Condition.....	35

TECHNICAL INFORMATION

Product Code	ITR208-0005 & ITR212-0005
Power Supply	100-250 VAC @50 Hz
Power Consumption	0.9 W
Number of Binary Inputs	ITR208-0005 -> 8 channels ITR212-0005 -> 12 channels
Virtual Inputs	ITR208-0005 -> 8 channels ITR212-0005 -> 12 channels
Number of Binary Outputs	ITR208-0005 -> 8 channels ITR212-0005 -> 12 channels
Contact Capacity	Inrush type (16 A, Inrush current 100 A)
Temperature Range	Operation (- 5°C ...45 °C) Storage (- 20°C ...70 °C)
Flammability	Non-flammable Product
Type of Protection	IP 20
Maximum Air Humidity	< 90 RH
Mounting	DIN Rail
Dimensions	59.3 x 86 x 157.8 mm (HxWxD) 9 DIN Units
Colour	Light Grey(RAL 7035)
Weight	390 gr
Contact Capacity	Inrush type (16A, Inrush current 100A)

1. PRODUCT DESCRIPTION

The 8/12 Channels Ethernet I/O Module is a versatile device which allows a variety of configurations. The ethernet module is intended to cover every automation requirement in a smart building for safe and efficient operations. The ethernet I/O module has been developed for providing the desired controls in the residence and hotel sectors. The usage of this devices guarantees the efficient management and provision of rooms. The device takes its energy from the 100-250 VAC mains line and does not need an external power supply. The device can communicate with the Interra touch panels and the Interra HomeServer via ethernet connection. In addition, the desired configurations for the inputs and outputs of the device can be made from the corresponding menus via the EIO Configuration software.

Consideration before use :

It is known that inrush current is very high for capacitive loads. If a capacity load too high is connected the device might be damaged. Therefore, before connecting a capacity load to the device, you must measure its inrush current and be sure the device can support it.

1.1. PRODUCT FUNCTIONS

- ON/OFF control can be made with every output of the ethernet I/O module.
- Toggle control can be made with every output of the ethernet I/O module.
- Each output of the Ethernet I / O module can be controlled with time dependent control.
- Shutter/blind 24 V configuration can be with 4 outputs of the ethernet I/O module.
- Shutter/blind 230 VAC configuration can be with 2 outputs of the ethernet I/O module.
- Up to 10 different scenarios can be created by performing the desired configurations.
- Logic relationships can be established between inputs, outputs and virtual inputs to perform different configurations.
- Last situation memory against power failure.

1.2. PRODUCT DIMENSIONS

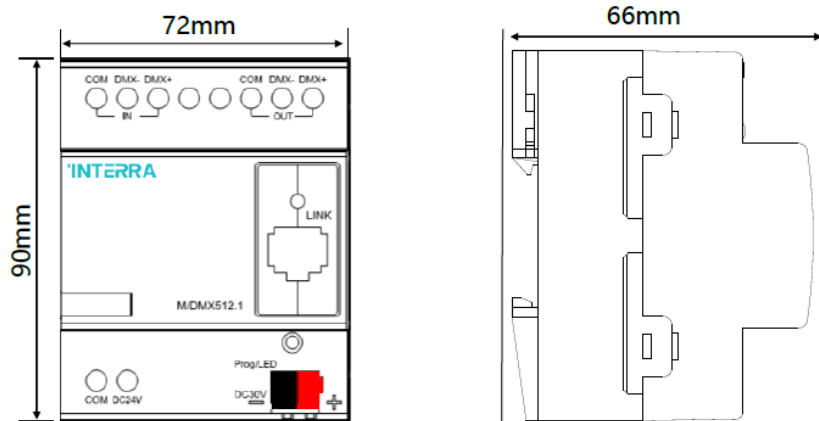

Fig 1 : Front and Side Appearances and Measures of the Device.

The numerical values showing the dimensions above are in mm.

1.3. CONNECTION DIAGRAM AND PROGRAMMING

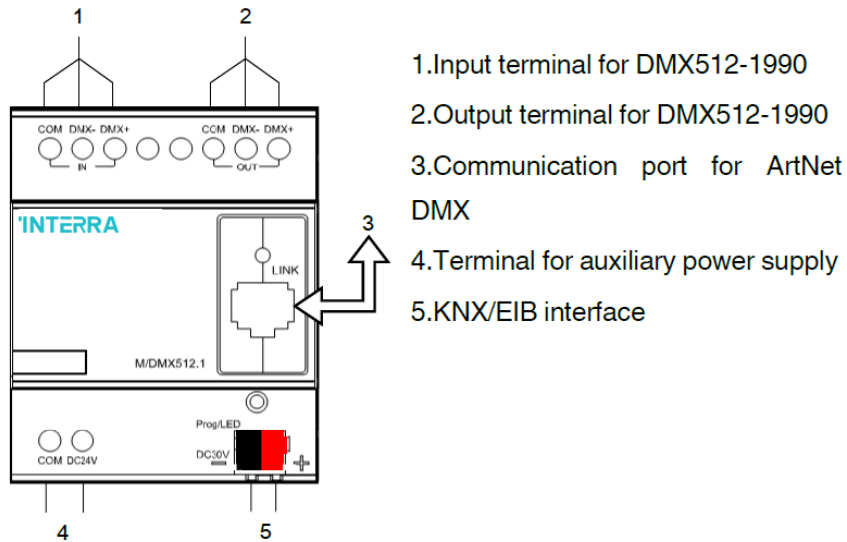

Fig 2 : KNX Connector, Programming LED and Button.

Connection to the device is via the KNX connector and dry contacts. Once the connections have been made correctly, the device can now be programmed. The programming button is pressed first, then the programming LED is illuminated after pressing. In this way, the ETS configuration can be loaded to the device.

2. MOUNTING





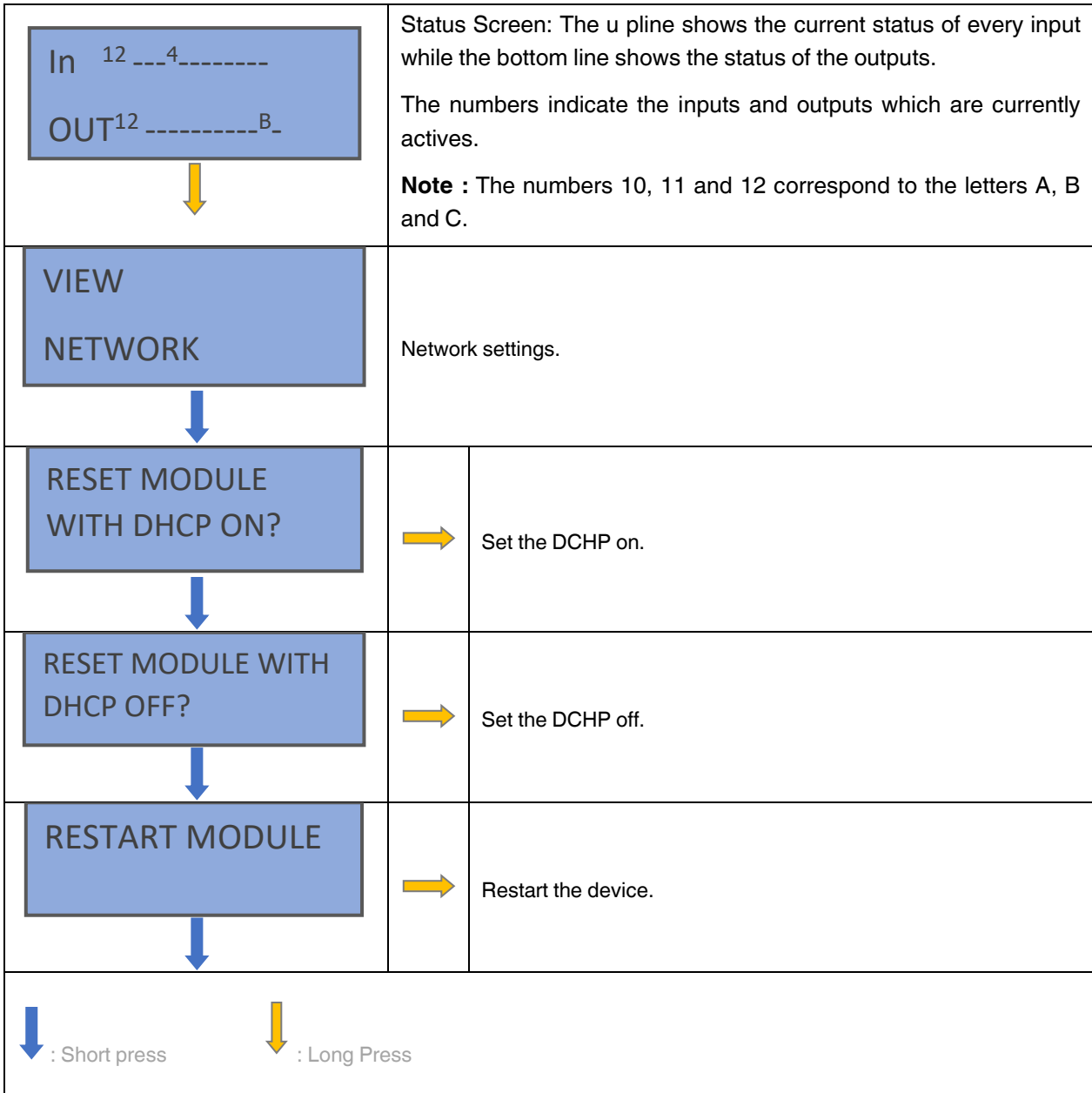

ITR208-0005 & ITR212-0005 – 8/12 Channels Ethernet I/O Module installation; The load cables and the KNX / EIB cables must be labeled and completely isolated from each other. The device must be installed on a DIN rail in the distribution board and cables must be connected for loads. After making sure that there is no short or open circuit, check that the KNX cable type is correct and not short-circuited. For the DMX interface, the device needs an extra 24V DC supply and if this is to be used, the power supply connections must be made correctly. After this process, the KNX cables must be connected with the correct color and all cables must be properly re-assembled. After the processes are finished, ensure that the KNX line is isolated from the AC line and other loads.

3. LCD MENU

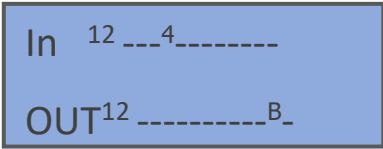
Via the LCD screen available, it is possible to know the status of the device channels and the network settings. Besides, the DHCP service can be set on or off. The different options are described below.

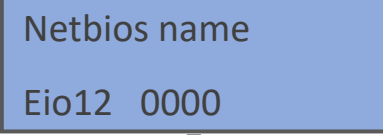
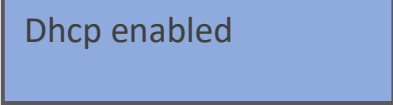

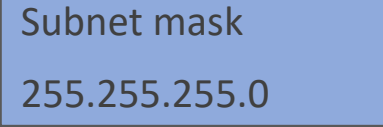
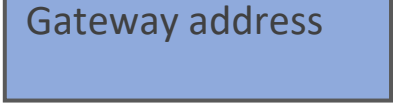
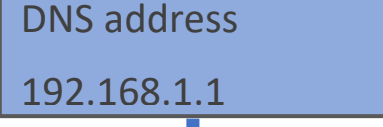
- Network Settings

 <p style="text-align: center;">↓</p>	<p>Status Screen: The up line shows the current status of every input while the bottom line shows the status of the outputs.</p> <p>The numbers indicate the inputs and outputs which are currently actives.</p> <p>Note : The numbers 10, 11 and 12 correspond to the letters A, B and C.</p>
 <p style="text-align: center;">↓</p>	<p>Network settings.</p>
 <p style="text-align: center;">↓</p>	<p>Device Hostname configured.</p>
 <p style="text-align: center;">↓</p>	<p>This screen shows whether the DHCP function is enabled or disabled.</p>
 <p style="text-align: center;">↓</p>	<p>IP address settings. This section shows the IP address configured. In this example the default IP address.</p>
 <p style="text-align: center;">↓</p>	<p>Subnet Mask settings. This screen shows the subnet mask configured. In this example the default subnet mask.</p>
 <p style="text-align: center;">↓</p>	<p>Gateway address settings. This section shows the gateway address configured. In this example the default gateway address.</p>
 <p style="text-align: center;">↓</p>	<p>DNS address settings. This section shows the DNS address configured. In this example the default DNS address.</p>
<p style="text-align: center;">  : Short press  : Long Press </p>	

4. USER INTERFACE

The complete configuration of the device is performed via a friendly user interface. “EIO12S.exe” application must be installed in the user computer. Ethernet connection is required.

Running this application, the next window is shown. For the first connection, it is necessary to insert the IP default address or the device default host name described above.

4.1. HOME

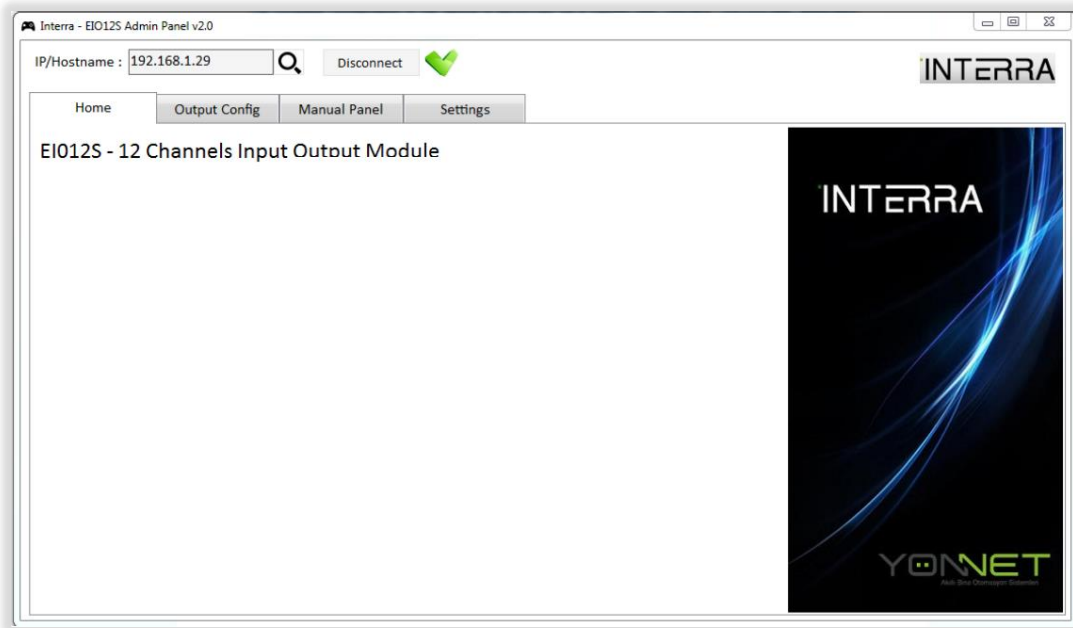

Fig 1 : EIO Configuration Software Home Section

It is also possible to make a search of the products available on the network via the lens button present in the “Home” window. In order to discover the devices available, it is necessary to define the IP range to make the search.

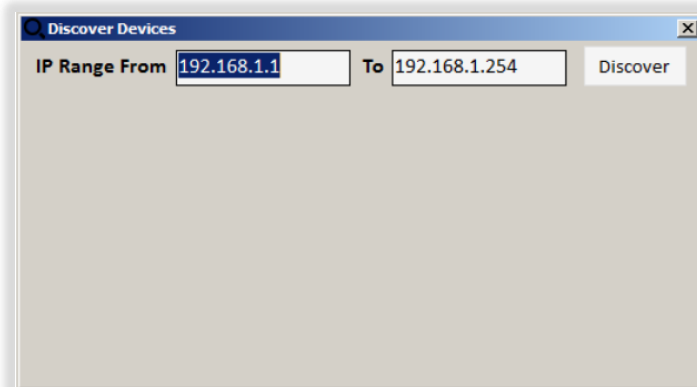

Fig 2 : EIO Configuration Software Discover Section

4.2. OUTPUT CONFIGURATION

In the “Output Config” window is where the related function for each output are defined.

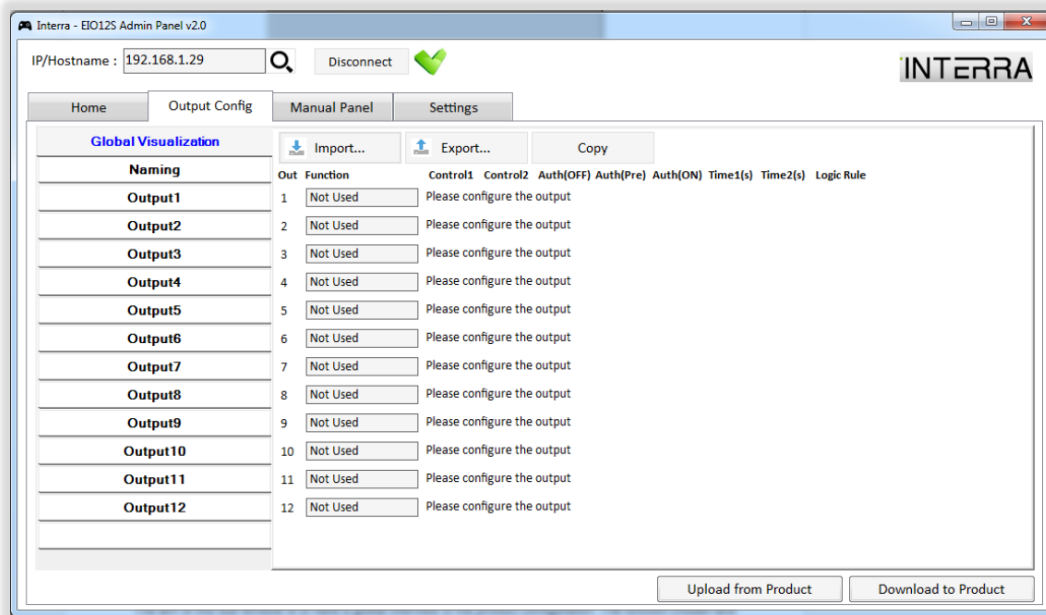

Fig 3 : EIO Configuration Software Discover Section

4.2.1. Global Visualization

The aim of using this sub window is to have a global overview of the product configuration. The function chosen and the main parameters of each output are shown here.

Via the button “Import” it is possible to import a new file (.I12) which content a full configuration of the product. This can be an old configuration previously saved. On the other hand, via the “Export” button, the current configuration of the product can be exported into a file and saved.

It is also possible to copy the configuration between different devices present on the network via option “Copy”. For this it is necessary to define the IP address of the product to be copied and the IP of the product where the copy will be done. After this and by pressing Copy, the 2 products will have the same configuration.

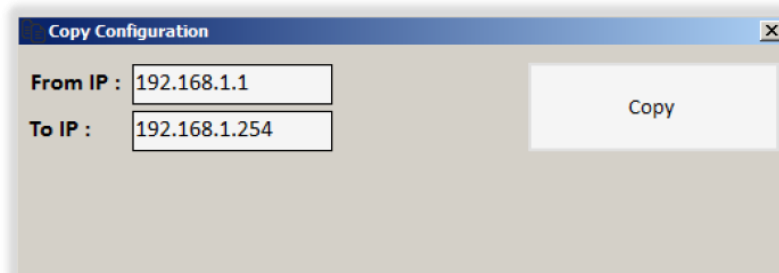

Fig 4 : EIO Configuration Software Copy Configuration

4.2.2. Naming

The description of every input and output can be written via this window. This will be used only as information.

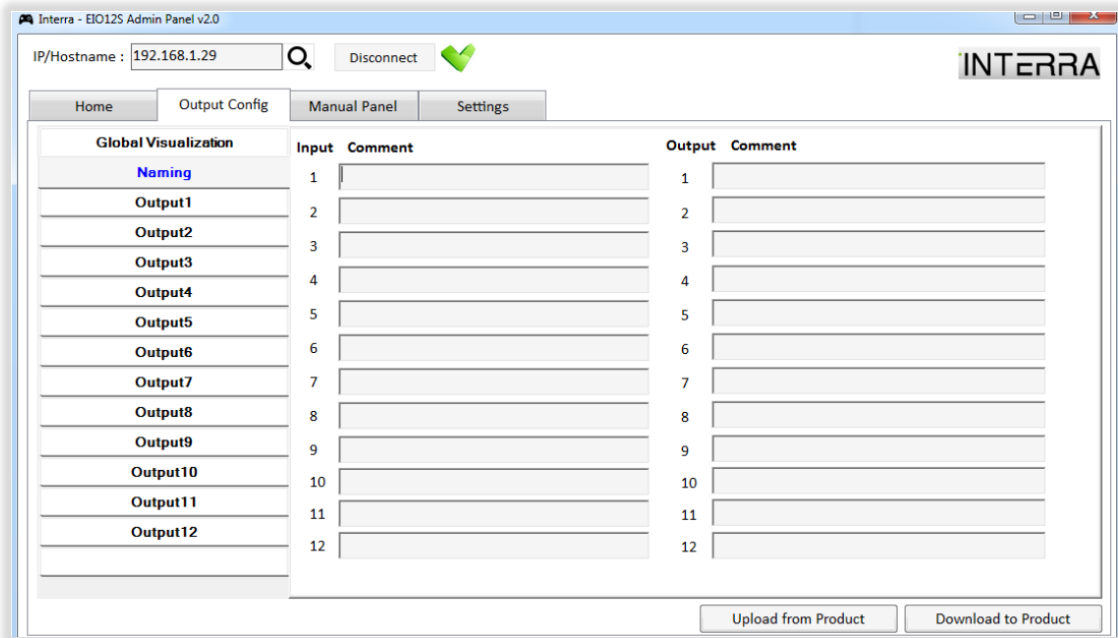

Fig 5 : EIO Configuration Software Output Config

4.2.3. Outputs

The exact functions of the outputs depend on the configuration that you establish in this window. Refer to section number 4 for more detailed information about the functions available.

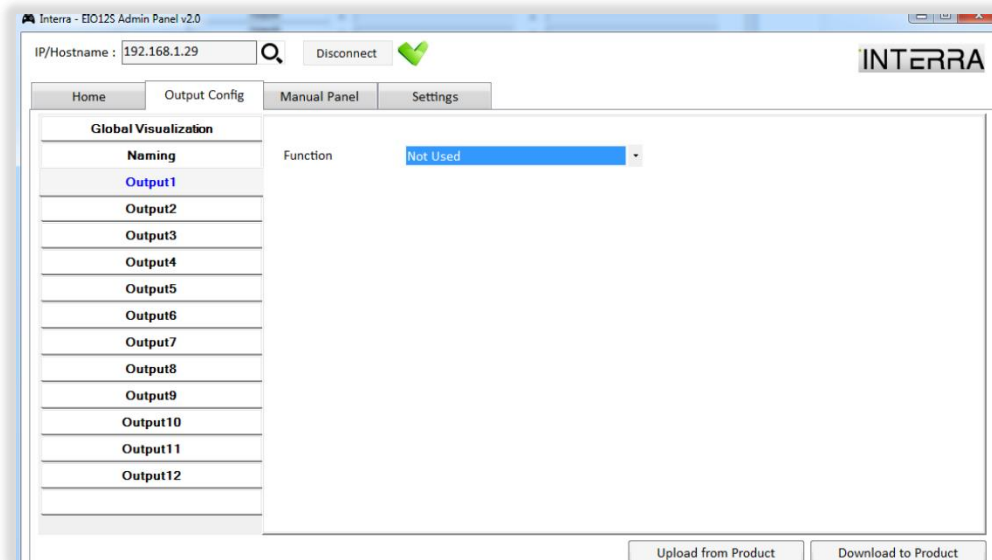

Fig 6 : EIO Configuration Software Function Configuration

4.3. MANUAL

The “Manual Panel” window shows the current status of every device channel and allows for forcing the virtual inputs.

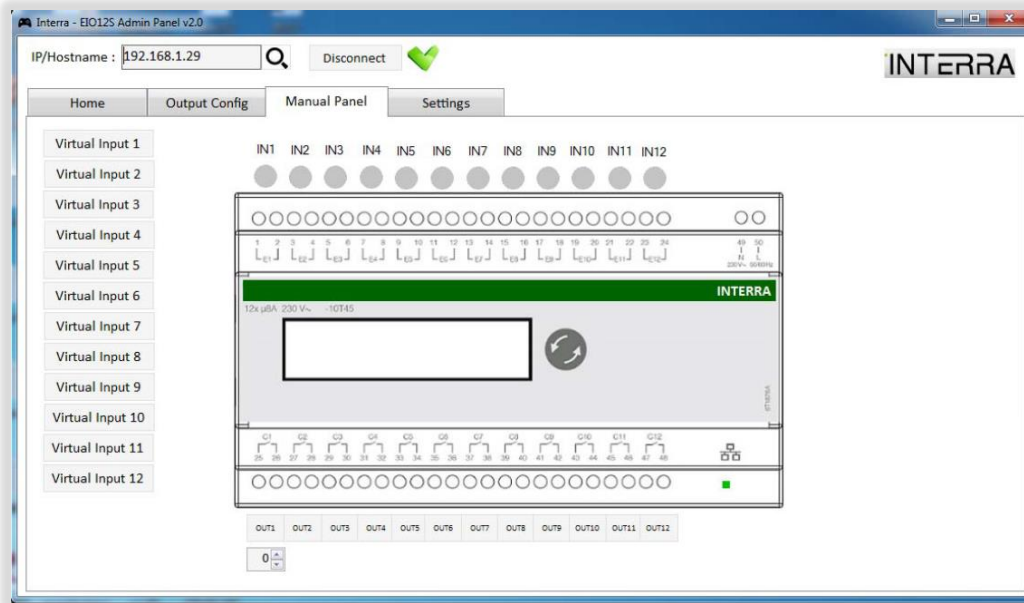

Fig 7 : EIO Configuration Software Manual Panel

- ✓ **Outputs** : Every output status is shown. When an output is active, the colour changes to green.
- ✓ **Inputs** : Every input status is shown. When an input is active, the colour changes to green.
- ✓ **Virtual Inputs** : Virtual inputs can be used as a logic elements in this window. These inputs can be modified from the buttons available on the left side or from remote connection over TCP sockets. Up to 4 simultaneous are possible.

4.4. SETTINGS

Network settings configuration and firmware update can be done through this window.

4.4.1. Network Settings

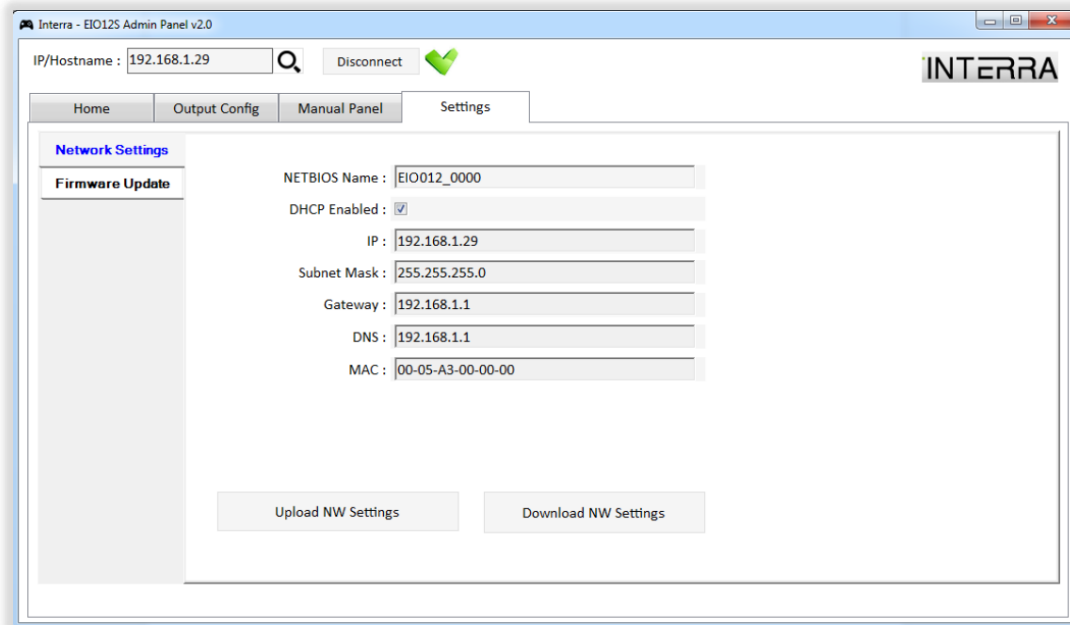

Fig 8 : EIO Configuration Software Network Settings

DHCP option can be enabled or disabled via the check box available. When DHCP is disabled the network configurations must be defined. Via the “Upload NW Settings” and “Download NW Settings” buttons, the network configuration can be loaded to the device or retrieved from it.

4.4.2. Firmware Update

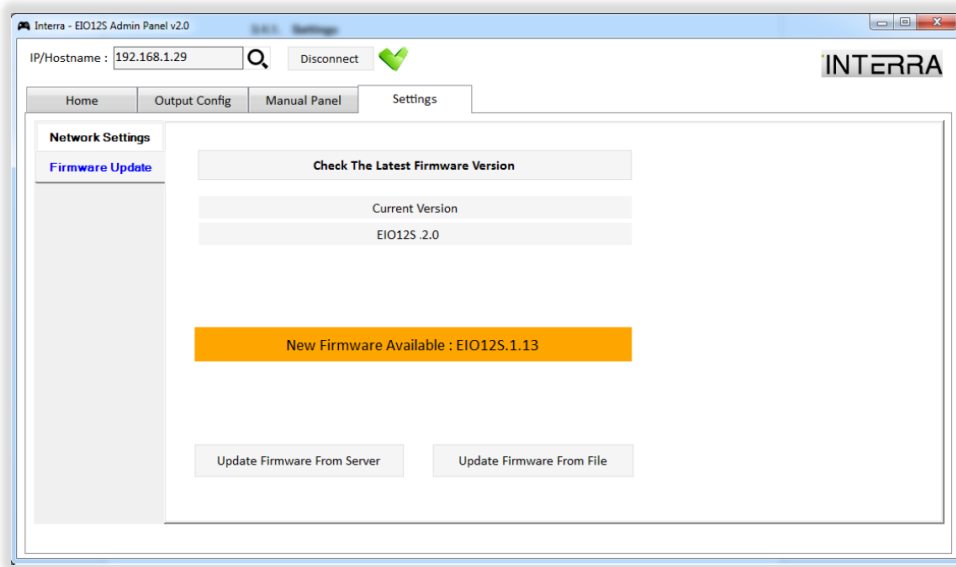

Fig 9 : EIO Configuration Software Firmware Update Settings

Through this window, it is possible to update the software. There are two options to do this:

- The application can check if there is any update available pressing the button “Get Current Firmware Version”. Once a new update has been found, pressing the button “Update Firmware”, the update will be load to the device.

Note : For this option internet connection is required and TFTP Client must be active in the computer. It is possible to activate this option in Control Panel/Programs and Features/Turn Windows features on or off.

- A new software update can be also loaded via a file. The manufacturer is able to provide a file that can be imported pressing the button “Update Firmware From File”.

5. FUNCTIONS DESCRIPTION

Several functions are available for the configuration of the product. Via the window “Output configuration” the functions can be set.

5.1. ON/OFF FUNCTION

5.1.1. Function Description

This function is available for all outputs. User can control any load connected to the dedicated output via on/off function. The load can be switched on or switched off.

5.1.2. Parameters List

PARAMETERS	DESCRIPTION	VALUES
Function	This parameter, is used to select the output function.	Not used On/Off Toggle Timer Shutters
Control Type	This parameter, is used to select the type of control.	Input Virtual Input Output Status Logic Rule
		IN1 IN2 IN3 IN4 IN5 IN6 IN7 IN8 IN9 IN10 IN11 IN12
		VIN1 VIN2 VIN3 VIN4 VIN5 VIN6 VIN7 VIN8 VIN9 VIN10 VIN11 VIN12
		OUT1 OUT2 OUT3 OUT4 OUT5 OUT6 OUT7

		OUT8 OUT9 OUT10 OUT11 OUT12
Control Polarity	This parameter, is used to select the polarity of control type.	1=Active,0=Deactivate 1=Deactivate,0=Active
Logic Rule	This parameter, is used to configure logic to control output.	-
Engaging Delay (s)	This parameter, is used to set an engaging delay.	0...65535
Release Delay (s)	This parameter, is used to set a release delay.	0...65535
Authorization (OFF)	This parameter, is used to configure authorization to control output.	- Input Virtual input Output status
		IN1 IN2 IN3 IN4 IN5 IN6 IN7 IN8 IN9 IN10 IN11 IN12
		VIN1 VIN2 VIN3 VIN4 VIN5 VIN6 VIN7 VIN8 VIN9 VIN10 VIN11 VIN12
		OUT1 OUT2 OUT3

		OUT4 OUT5 OUT6 OUT7 OUT8 OUT9 OUT10 OUT11 OUT12
Polarity	This parameter, is used to select the polarity of authorization.	1=Active,0=Deactivate 1=Deactivate,0=Active

5.1.3. Configuration Description

The dedicated output can be controlled in 4 different ways. Via the parameter “control type” the selection of input, virtual input, output status or logic rule can be set.

Example of logic rule : IN3=VIN2.

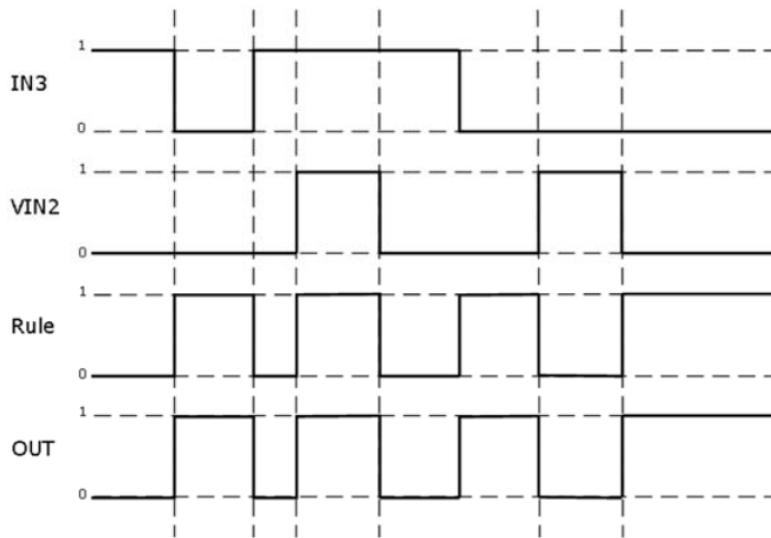

Fig 10 : A Logic Rule Example

5.1.3.1. Delays Configuration

It is possible to configure 2 types of delays via the parameters “Engaging delay” and “Release delay”.

- ✓ **Engaging delay (s)** : Once the control is active in order to switch on the output, the output will be activated after the time configured in the engaging delay parameter.

- ✓ **Release delay (s)** : Once the control is active in order to switch off the output, the output will be deactivated after the time configured in the release delay parameter.

The details of the delays behaviour can be observed in the following drawing :



Fig 11 : Delay Behaviour

5.1.3.2. Authorization description

The authorization allows the user to define a signal as the main controller. Only when the authorization is true, the normal control of the output is allowed.

Via the parameter “authorization type” the selection of input, virtual input or output status can be set.

With this option, the status of the dedicated output takes the value 0 while the authorization is not activated. Once the authorization is true, the output can be controlled as normally.

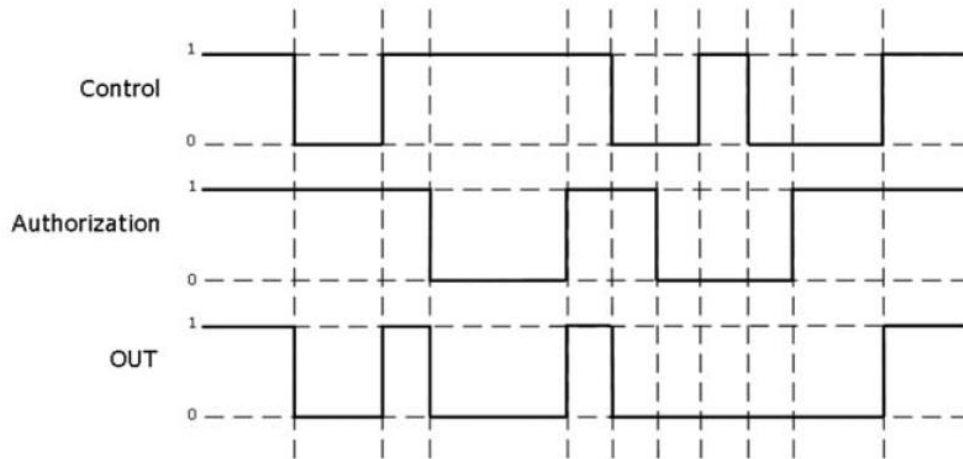

Fig 12 : Authorization Example

5.2. TOGGLE FUNCTION

5.2.1. Function Description

This function is available for all outputs. User can control any load connected to the dedicated output via toggle function. The load can be switched on or switched off.

5.2.2. Parameters List

PARAMETERS	DESCRIPTION	VALUES
Function	This parameter, is used to select the output function.	Not used On/Off Toggle Timer Shutters
Edge Type	This parameter, is used to select the type of edge.	Falling edge Rising edge
After Power Failure	This parameter, is used to select the action after power failure.	On Off Previous Value
Control Type	This parameter, is used to select the type of control.	Input Virtual Input Output Status Logic Rule
		IN1 IN2 IN3 IN4 IN5 IN6 IN7 IN8 IN9 IN10 IN11 IN12
		VIN1 VIN2 VIN3 VIN4 VIN5 VIN6 VIN7

		VIN8 VIN9 VIN10 VIN11 VIN12
		OUT1 OUT2 OUT3 OUT4 OUT5 OUT6 OUT7 OUT8 OUT9 OUT10 OUT11 OUT12
Control Polarity	This parameter, is used to select the polarity of control type.	1=Active,0=Deactivate 1=Deactivate,0=Active
Logic Rule	This parameter, is used to configure logic to control output.	-
Engaging Delay (s)	This parameter, is used to set an engaging delay.	0...65535
Release Delay (s)	This parameter, is used to set a release delay.	0...65535
Authorization (OFF, Previous Value or ON)	This parameter, is used to configure authorization to control output.	- Input Virtual input Output status
		IN1 IN2 IN3 IN4 IN5 IN6 IN7 IN8 IN9 IN10 IN11 IN12
		VIN1 VIN2 VIN3

		VIN4 VIN5 VIN6 VIN7 VIN8 VIN9 VIN10 VIN11 VIN12
		OUT1 OUT2 OUT3 OUT4 OUT5 OUT6 OUT7 OUT8 OUT9 OUT10 OUT11 OUT12
Polarity	This parameter, is used to select the polarity of authorization.	1=Active,0=Deactivate 1=Deactivate,0=Active

5.2.3. Configuration Description

The dedicated output can be controlled in 4 different ways. Via the parameter “control type” the selection of input, virtual input, output status or logic rule can be set.

5.2.3.1. Edge Type

Via the “Edge type” parameter, the type of toggle to be used can be selected:

- ✓ **Falling edge** : This function allows the output to behave as toggle falling edge. Due to the falling edge detection, the output will change its status only when the control changes from 1 to 0. The details of this behaviour can be observed in the following drawing:

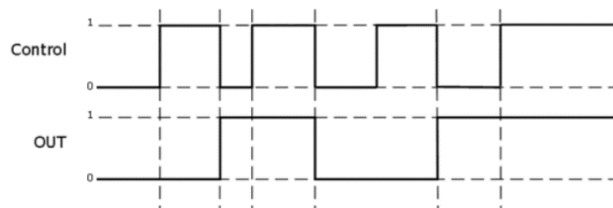

Fig 13 : Falling Edge Behaviour

- ✓ **Rising edge** : This function allows the output to behave as toggle rising edge. Due to the rising edge detection, the output will change its status only when the control changes from 0 to 1. The details of this behaviour can be observed in the following drawing:

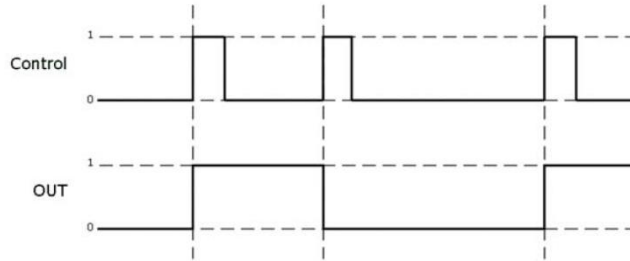

Fig 14 : Rising Edge Behaviour

5.2.3.2. Action After Power Failure

The reaction of the output after power failures can be set via the parameter “After Power Failure”:

- ✓ **ON**: The output will be switched ON after power failures.
- ✓ **OFF**: The output will be switched OFF after power failures.
- ✓ **Previous value**: The output will recover the previous status after power failures.

5.2.3.3. Delays Configuration

It is possible to configure 2 types of delays via the parameters “Engaging Delay” and “Release Delay”.

- ✓ **Engaging delay (s)**: Once the control is active in order to switch on the output, the output will be activated after the time configured in the engaging delay parameter.
- ✓ **Release delay (s)**: Once the control is active in order to switch off the output, the output will be deactivated after the time configured in the release delay parameter.

The details of the delays behaviour can be observed in the following drawing:

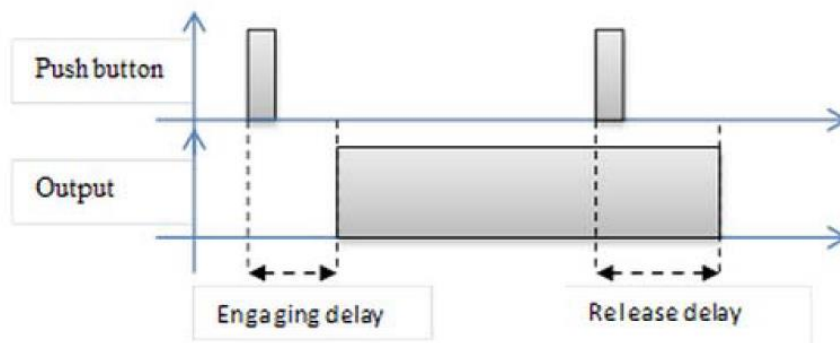

Fig 15 : Engaging and Release Delay Behaviour

5.2.3.4. Authorization Description

The authorization allows the user to define a signal as the main controller. Only when the authorization is true, the normal control of the output is allowed.

Via the parameter “authorization type” the selection of input, virtual input or output status can be set.

With this option, the status of the dedicated output takes the value 0 while the authorization is false. For toggle function, 3 types of authorization are available. Via the parameter “Action if authorization=1”, the reaction of the output when the authorization takes the value 1 can be selected.

- ✓ **ON:** The output is switched off.
- ✓ **OFF:** The output is switched on.
- ✓ **Previous value:** The output takes the previous value stored.

5.3. TIMER FUNCTION

5.3.1. Function Description

This function is available for all outputs. User can control any load connected to the dedicated output via Timer function. The load can be switched during a certain time.

5.3.2. Parameters List

PARAMETERS	DESCRIPTION	VALUES
Function	This parameter, is used to select the output function.	Not used On/Off Toggle Timer Shutters
Control Type	This parameter, is used to select the type of control.	Input Virtual input Output Status Logic Rule
		IN1 IN2 IN3 IN4 IN5 IN6 IN7 IN8 IN9

		IN10 IN11 IN12
		VIN1 VIN2 VIN3 VIN4 VIN5 VIN6 VIN7 VIN8 VIN9 VIN10 VIN11 VIN12
		OUT1 OUT2 OUT3 OUT4 OUT5 OUT6 OUT7 OUT8 OUT9 OUT10 OUT11 OUT12
Control Polarity	This parameter, is used to select the polarity of control type.	1=Active,0=Deactivate 1=Deactivate,0=Active
Logic Rule	This parameter, is used to configure logic to control output.	-
Timer Duration (s)	This parameter, is used to set the timer function.	0...65535
Ext. Limitation	This parameter, is used to select the number of times allowed for the duration extension.	Disabled No limitation 1 extension 2 extension 3 extension 4 extension 5 extension
Pre Warning	This parameter, is used to enable or disable the pre warning function.	Disabled Enabled
Pre Warning Duration (s)	This parameter, is used to set the pre warning duration.	0 (0...65535)

<p>Authorization (OFF)</p>	<p>This parameter, is used to configure authorization to control output.</p>	<ul style="list-style-type: none"> - Input Virtual input Output status
		<ul style="list-style-type: none"> IN1 IN2 IN3 IN4 IN5 IN6 IN7 IN8 IN9 IN10 IN11 IN12
		<ul style="list-style-type: none"> VIN1 VIN2 VIN3 VIN4 VIN5 VIN6 VIN7 VIN8 VIN9 VIN10 VIN11 VIN12
		<ul style="list-style-type: none"> OUT1 OUT2 OUT3 OUT4 OUT5 OUT6 OUT7 OUT8 OUT9 OUT10 OUT11 OUT12
<p>Polarity</p>	<p>This parameter, is used to select the polarity of authorization.</p>	<p>1=Active,0=Deactivate 1=Deactivate,0=Active</p>

5.3.3. Configuration Description

The dedicated output can be controlled in 4 different ways. Via the parameter “control type” the selection of input, virtual input, output status or logic rule can be set.

5.3.3.1. Timer Operation

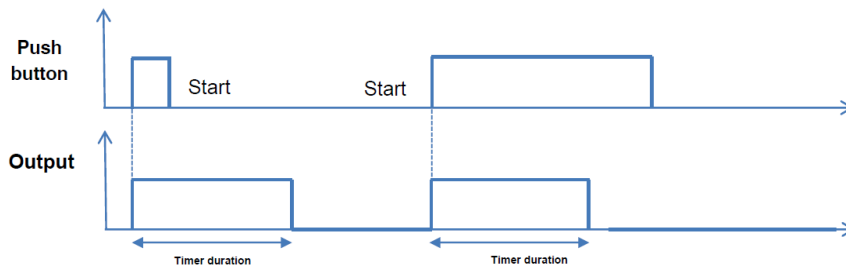

Fig 16 : Timer Operation Behaviour

5.3.3.2. Pre Warning

This functionality allows to inform that the timer will stop in x seconds (“Cut-off pre warning duration” parameter). The information is done through the inversion of the output state (binary product).

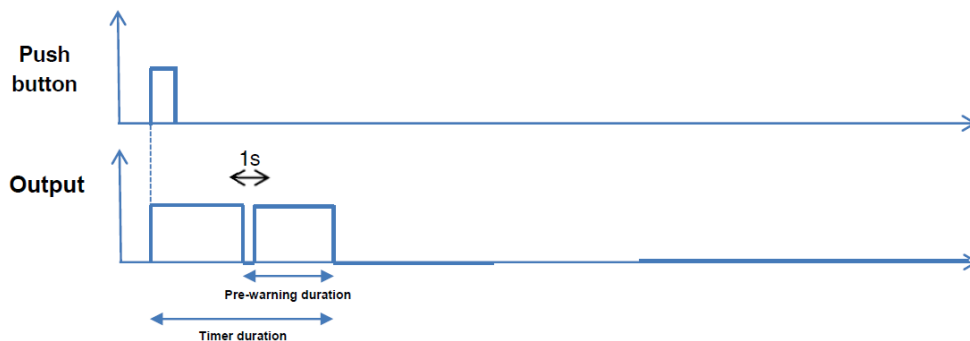

Fig 17 : Pre Warning Behaviour

5.3.3.3. Timer Retriggerability

If multiple commands to start the timer are received in an interval of 10 seconds from the first boot received, the effective delay is equal to the value of the parameter “Timer duration” multiplied by the number of command “Start” received, up to parameter value “Timer duration extension limitation”, during these 10 seconds.

Any new command “Start” or any new sequence of several “Start” performed in less than 10 seconds, received after the 10-second interval timer replaces the previous one with the new value.

This functionality can be deactivated through the parameter “Activation of timer retriggerability”.

Ex 1 :

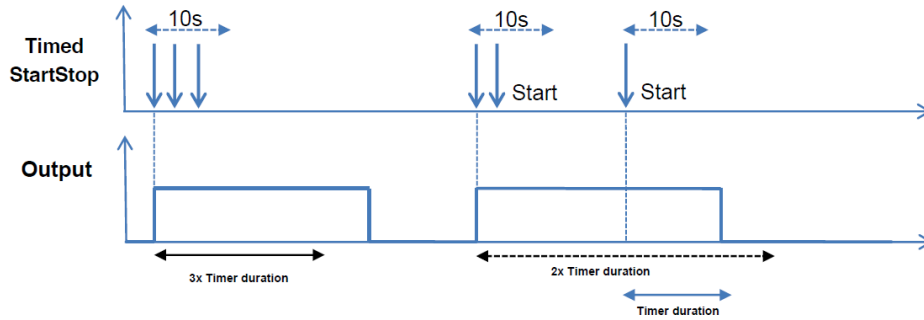

Fig 18 : Timer Retriggerability

Ex 2 :

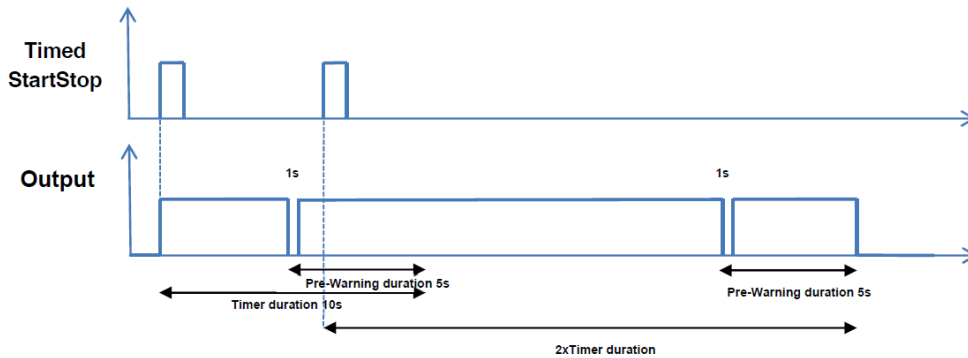

Fig 19 : Timer Retriggerability with Pre-Warning

5.3.3.4. Authorization description

The authorization allows the user to define a signal as the main controller. Only when the authorization is true, the normal control of the output is allowed.

Via the parameter “authorization type” the selection of input, virtual input or output status can be set.

With this option, the status of the dedicated output takes the value 0 while the authorization is not activated. Once the authorization is true, the output can be controlled as normally.

5.4. SHUTTER FUNCTION

5.4.1. Function Description

User can control 230V AC and 24V DC shutters. It is necessary 2 dedicated outputs to control 230V AC shutters and 4 dedicated outputs for 24V DC shutters. The user can move up and down the shutter and adapt it to its needs.

The need of 2 or 4 consecutive outputs conditions the configuration.

- ✓ **2 Outputs Shutter** : Outputs 1, 3, 5, 7, 9 and 11 are available.
- ✓ **4 Outputs Shutter** : Outputs 1, 5 and 9 are available.

5.4.2. Parameters List

PARAMETERS	DESCRIPTION	VALUES
Function	This parameter, is used to select the output function.	Not used On/Off Toggle Timer Shutters
Shutter Type	This parameter, is used to select the type of shutter.	2 outputs 230V AC 4 outputs 24V DC
Control mode	This parameter, is used to select the control mode.	2 buttons 1 button
Up/Down Button	This parameter is used to specify the inputs to which the buttons are matched.	IN1 / VIN1 IN2 / VIN2 IN3 / VIN3 IN4 / VIN4 IN5 / VIN5 IN6 / VIN6 IN7 / VIN7 IN8 / VIN8 IN9 / VIN9 IN10 / VIN10 IN11 / VIN11 IN12 / VIN12
Up Button	This parameter is used to specify the input to which the up button is matched.	IN1 / VIN1 IN2 / VIN2 IN3 / VIN3 IN4 / VIN4 IN5 / VIN5 IN6 / VIN6 IN7 / VIN7 IN8 / VIN8 IN9 / VIN9 IN10 / VIN10 IN11 / VIN11 IN12 / VIN12
Down Button	This parameter is used to specify the input to which the down button is matched.	IN1 / VIN1 IN2 / VIN2 IN3 / VIN3 IN4 / VIN4 IN5 / VIN5 IN6 / VIN6 IN7 / VIN7

		IN8 / VIN8 IN9 / VIN9 IN10 / VIN10 IN11 / VIN11 IN12 / VIN12
Up Duration (s)	This parameter, is used to configure the up duration.	0... 120 ...65535
Down Duration (s)	This parameter, is used to configure the down duration.	0... 120 ...65535
Enabling Condition	This parameter, is used to select the type of enabling condition.	Input Virtual Input Output Status Logic Rule
		IN1 IN2 IN3 IN4 IN5 IN6 IN7 IN8 IN9 IN10 IN11 IN12
		VIN1 VIN2 VIN3 VIN4 VIN5 VIN6 VIN7 VIN8 VIN9 VIN10 VIN11 VIN12
		OUT1 OUT2 OUT3 OUT4 OUT5 OUT6 OUT7

		OUT8 OUT9 OUT10 OUT11 OUT12
Control Polarity	This parameter, is used to select polarity of the enabling condition.	1=Active,0=Deactivate 1=Deactivate,0=Active

5.4.3. Configuration Description

The shutter connected to the dedicated outputs can be controlled with 1 or 2 inputs. Via the parameter “Control mode” this configuration can be set.

5.4.3.1. Configuration with 1 button

User can both raise and lower the blind with a single push-button. Each short press will send a value following this sequence “up”, “stop”, “down” and “stop”. The current direction of movement always depends on the previous action.

If the shutter is being raised and another short press occurs before the up duration has been reached, this new press will stop the movement. The same happens if the shutter is being lowered.

Via the parameter “Control type 1 (Up/Down)” the input which will control the shutter can be selected. The corresponding virtual input is automatically associated too. (Example: Input 1 is selected in the parameter “Control type 1 (Up/Down)” to control a shutter. Automatically Virtual Input 1 is associated to control the same shutter.

5.4.3.2. Configuration with 2 buttons

Two inputs are necessary for this option.

With the combination of both push buttons, the shutter can be lowered or raised. One input will be dedicated to lower the shutter while the other will raise it.

- **Long press:** [>500ms]

With a long push button action the shutter is lowered or raised. When push button is released, the shutter does not stop. The motion continues until the motion duration is elapsed or the push button is pressed with a short press.

- **Short press:** [<500ms]

A short push button action ends a current motion or adjusts the shutter by one step if it is currently stopped.

5.4.3.3. Motion Duration

The time duration for both movements, Up and Down, can be parameterized via the parameters “Up duration (s)” and “Down duration (s)”.

Inversion time value = 1 sec.

5.4.3.4. Enabling Condition

An enabling condition can be defined to authorize the control of the shutter. Only when the control type is activated, the normal control of the shutter is allowed.

CONTACT INFORMATION

THE INTERRA WEB SITE

Interra provides documentation support via our web site www.interra.com.tr. This web site is used as a means to make files and information easily available to customers. Accessible by using your favorite Internet browser, the web site contains the following information:

- Information about our products and projects.
- Overview of Interra company and values.
- Product Support: Data sheets, product manuals, application descriptions, latest software releases, ETS databases and archived software.

Europe, Turkey

Interra

Cumhuriyet Mah. Kartal Cad. No:95/1 Simkan Plaza 34876 Kartal/İstanbul

Tel: +90 (216) 326 26 40 Fax: +90 (216) 324 25 03

Web address: <http://www.interra.com.tr/>